

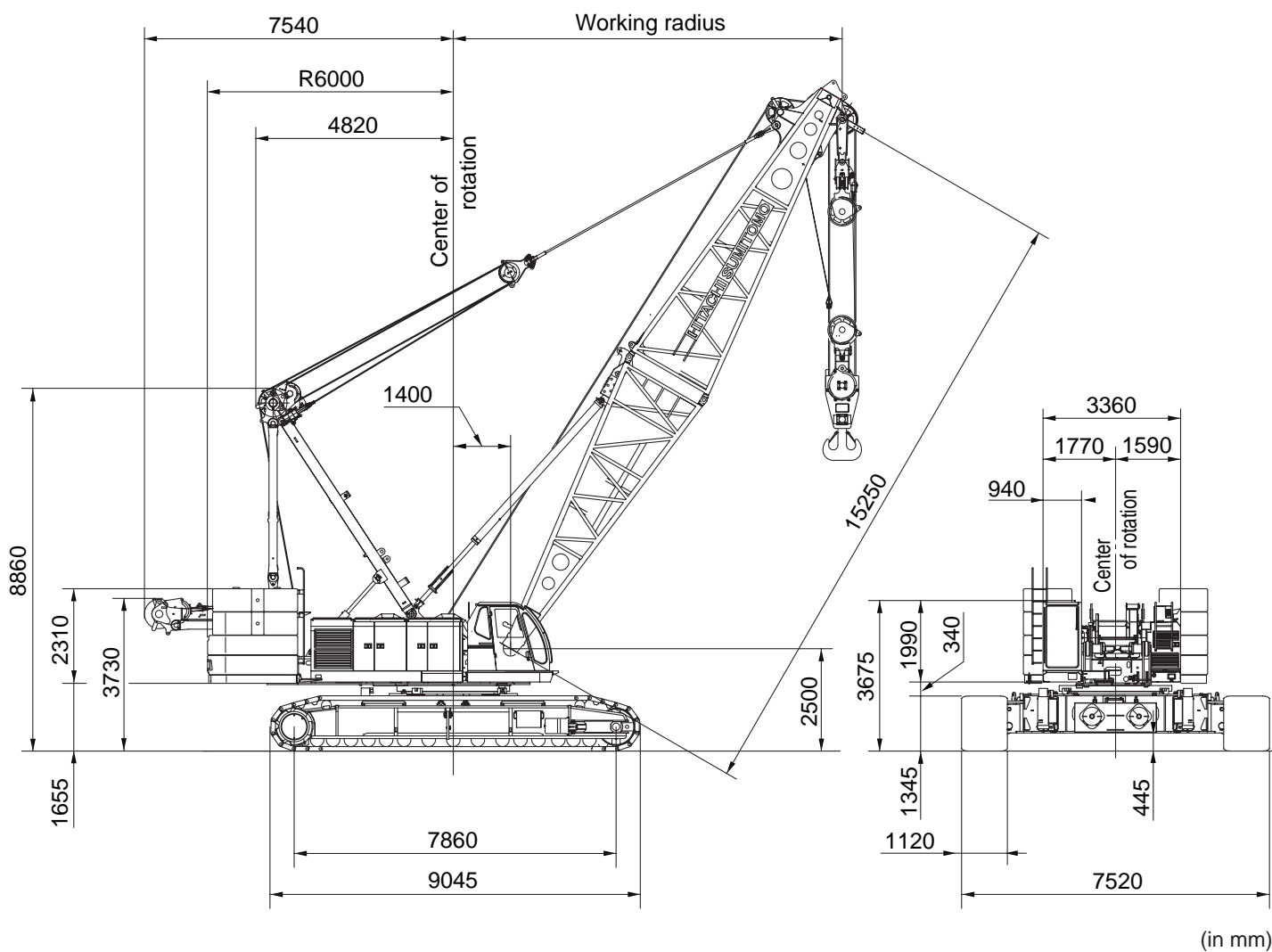

SCX2500

250-M ton Hydraulic Crawler Crane & Cable Excavator

General Dimensions:



Specifications

HITACHI SUMITOMO

SCX2500

Basic
Machine

Superstructure

UPPER REVOLVING FRAME:

All-welded, precision machined, robust construction. A machined surface provided for mounting load hoist and boom hoist assemblies, and mounting itself on turntable bearing.

TURNTABLE BEARING WITH INTERNAL SWING GEAR:

Single shear ball type; inner race of turntable bearing with integral, internal swing (ring) gear bolted to carbody frame, and outer race of turntable bearing bolted to upper revolving frame.

CONTROL SYSTEM:

System contains one set each of duplicate and triplicate tandem valves which direct oil to various machine function and are actuated by control levers via remote controlled hydraulic servo for all motions. Working speeds can be precisely controlled by motorcycle type throttle and pilot-operated arm chair single axis control levers in cooperation with "SC" controller that varies engine rpm and hyd. pump discharge simultaneously, or varies just hyd. pump discharge while keeping engine rpm. System also takes unique EEP SA (Electrical Engine Pump Sensing Analyzer) to maximizes drum horsepower, and reduces horsepower loss with eliminating the possibility of engine stall.

Pump control system — By "SC" controller that provides two modes of engine-pump control.

MODE I:

The SC Controller is normally programmed to vary the engine speed and pump discharge simultaneously. Simply twisting the grip advances the engine to maximum speed and the hydraulic pumps to maximum flow at the same time. This mode is suitable to precision crane work.

MODE II:

By activating a switch, it is able to vary just the pump discharge by means of the grip throttle, while keeping engine speed fixed. Mode II is convenient for operations such as lifting magnet and bucket work, where the engine is normally run at full throttle.

HYDRAULIC SYSTEM:

System provided with three variable displacement axial piston pumps and one fixed displacement duplicate tandem gear pump for both independent and combined operations of all functions. Gear pump also used for system valves and cylinder controls.

Main/aux. crane hoist motors — Variable displacement axial piston motor with counterbalance valve and spring-applied/hydraulically released multiple wet-disc type automatic brake.

Boom hoist motor — Twin-designed motor with axial piston type with counterbalance valve and

spring-applied/hydraulically released multiple wet-disc type automatic brake.

Swing motor — Two; axial piston type with spring-applied/hydraulically released multiple wet-disc type manually controlled brake.

Travel motors — Shoe-in design; axial piston motor with brake valve and spring-applied/hydraulically released multiple wet-disc type automatic brake.

Oil cooler — Located at right-rear of machinery room as separated from engine radiator together with an independent autcooling fan for better cooling efficiency and heat balance.

Independent hyd. circuits — Available in between hydraulic circuits of P1 main pump and front main drum winch motor, and between P2 main pump and rear main drum winch motor.

Hydraulic oil reservoir — 410 liters capacity.

LOAD HOIST ASSEMBLY:

Front and rear main operating drums driven by independent hydraulic motor of bi-directional, variable displacement axial piston motor through 2-stage planetary reduction gear units powering the rope drum in either direction for hoisting and lowering load. Each of drum sized in same dimension.

Brakes — Spring-applied, power hydraulically released multiple wet-disc type automatic brake; provided within hyd. motor;

Clutches — Optional extra; internal expanding, self-adjusting, mono-band design with non-asbestos lining; spring-applied, power hydraulically released. Available for a true gravity free-fall operation in functional combination with optional “ external contracting band type brakes ”.

External contracting band type brakes — Optional extra; required together with optional “ clutches ” for a true gravity free-fall operation. Instead of standardized automatic brake, an external contracting band type brake with 1,270mm dia. by 170mm wide brake drum and non-asbestos lining operated by power hydraulically assisted foot pedal with locking latch is designed. Two brake modes are available; for crane operation, automatic brake, spring-applied, power hydraulically released is applied when control lever is in neutral position, and for bucket operation, free-fall is available in the above control lever position.

Drums — One piece, parallel grooved lagging with locking ratchet wheel cast integral; mounted on drum shaft through anti-friction bearings.

Drum locks — Power hydraulically operated automatic pawl as std. while electrically controlled pawl is designed i/o automatic in a case of two main operating drums with optional free-fall function.

Drum rollers — Optional extra; available for right cable winding onto drums.

BOOM HOIST ASSEMBLY:

Twin-drum design; driven by two bi-directional, axial piston hydraulic motor through 2 sets of 2-stage planetary reduction gear unit powering the rope drum in either direction for hoisting and lowering boom.

Brake — Spring-applied, power hydraulically released multiple wet-disc type automatic brake.

Drum — One piece, twin-designed parallel grooved with locking ratchet wheel cast integral; mounted on drum shaft through anti-friction bearings.

Drum lock — Power hydraulically operated automatic pawl.

SWING:

Driven by two units of bi-directional, axial piston hydraulic motors through 2 sets of planetary reduction gear unit powering swing pinion. Swing pinion meshes with internal teeth of swing (ring) gear of turntable bearing inner race.

Brakes — Spring-applied, power hydraulically released multiple wet-disc type; provided on each of hydraulic motor.

Swing speed control — Max. swing speed can be tuned to according to arbitrary value that is electrically controlled by dialing, and then varies pump discharge.

Lock — Mechanically operated drop pin.

Speed — 1.7min^{-1} <1.7rpm>

GANTRY:

A-frame type; raised and lowered by power hydraulic cylinders.

OPERATOR'S CAB:

Swing-away design to set a 3.19-meter overall width of superstructure for a good transport; 940mm wide, acoustically treated, all new stamped, automotive type, full-vision, cushion rubber mounted, well-ventilated, full compartment, roomy operator's cab with large curved front window; provided with an arrangement of “SC” control/swing lever, sunvisor, sunshade, rear-view mirrors, intermittent dual window shield wipers with washer on both front and roof windows, and roll-down window on sliding door.

Instrument panel — Contains engine monitoring lamps, display panel of SML-10 Load Moment Limiter, and other necessary controllers and switches.

Operator's seat — Full adjustable reclining seat.

Air-conditioner — Optional extra; built-in type full air-conditioning.

Heater — Optional extra; hot water type.

Anemometer — Optional extra; recommended for luffing towercrane attachment.

Stone guard — Optional extra; stainless steel-make. This is available for operator's cab protection from outside obstacles.

AM/FM radio — Provided as std. with clock.

Fire extinguisher — Optional extra; powder type with 1kg capacity.

MACHINERY CAB:

Equipped with hinged doors on both sides for machinery access and inspection; tape-type non-skid material applied to the roof.

CATWALKS:

Optional extra; hitched in place along both sides of machinery cab.

HYDRAULIC TAGLINE WINDER:

Optional extra; provided in front of upper revolving frame, and this is available for

preventing a shake of suspended load like clamshell bucket by an 10mm dia. tug cable with light force.

COUNTERWEIGHTS:

Weighs 86.3ton consisting of an iron base plate of 10.9ton and 8 blocks, cast, removable, corner-rounded design and eight blocks consist of "A" (10,900kg), "B" (10,900kg), "C" (10,800kg), "D" (10,800kg), "E" (8,500kg), "F" (8,100kg), "G" (7,900kg) and "H" (7,500kg).

AUXILIARY WEIGHT:

Weighs 1.7ton; mounted on a part of upper revolving frame.

ELECTRICAL SYSTEM:

24-volt negative ground system; provided with two maintenance free 12-volt batteries.

LIGHTING SYSTEM:

Includes following lights.

- Two 70 W working lights;
- One 10 W interior cab light.

POWER UNIT:

Make & Model	Mitsubishi 6D24-TL
Type	Water-cooled, 4-cycle, direct injection, turbo-charged, diesel w/automatic cooling fan
No. of Cylinders	Six (6)
Bore & Stroke	130 mm × 150 mm
Displacement	11,945 cc
Rated Output	235 kW/2,000 min ⁻¹ 320 ps/2,000 rpm
Maximum Torque	1,245 N·m/1,400 min ⁻¹ 127 kgf-m/1,400 rpm
Fuel Tank	500 liters

***Note**

6D24-TLU2E
EU Emission Regulations for Off-road Diesel Engines- Stage 2
6D24-TLE2A
Japanese Emission Standards For Diesel Construction Equipment Stage 2.

Undercarriage

CARBODY FRAME:

All-welded, precision machined, box type construction; A machined surface provided for mounting turntable bearing.

CARBODY JACK-UP DEVICE:

Contains four hydraulic jack cylinders attached on carbody jack cylinder beams for extending/retracting, and disassembling/assembling ease of crawler side frames.

Pontoon — All-welded construction; four pontoons each stored at an inside part of jack cylinder beams.

CRAWLER SIDE FRAMES:

All-welded, box type construction, precision machined; Cylinder-joint system can fix side frame and lower frame through operation of cylinders after side frame is hung on guide-pin of lower frame for assembly.

Joint cylinders — For assisting in connection and disconnection of side frames.

Crawler side steps — Provided at both ends of the frames for easy access to superstructure.

CARBODY WEIGHT:

Weight 14ton; made of steel scrap with concrete pouring. 7ton each mounted at front and rear of the carbody.

DRIVE SPROCKETS:

Cast steel, heat treated; one per side frame. Track drive sprocket assembly bolt-coupled to 3-stage planetary reduction gear unit outer case as an integral part of shoe-in type traction motor. Sealed between parts of rotation and non-rotation of the motor with floating seal.

IDLER WHEELS:

Cast steel, heat treated; one per side frame. Mounted on two bronze bushings with floating seals for lifetime lubrication.

TRACK ROLLERS:

Fifteen per side frame; each heat treated cast steel, with double flange design. All rollers mounted on two bronze bushings with floating seals for lifetime lubrication.

CARRIER ROLLERS:

Four per side frame; each heat treated cast steel. Two rollers are double flanged while other two rollers are single flanged type. All rollers mounted on bronze bushing(s) with floating seals for lifetime lubrication.

TRACKS:

Heat treated, self-cleaning, multiple hinged track shoes joined by full floating pins; 58 pcs. per side frame.

Shoe width — 1,120mm wide as standard.

Track adjustment — Manual adjustment device with oil jack and shim plate packs is standardized.

As an optional extra, that idler wheels automatically adjusted while operation by means of hyd. cylinders actuated by power hydraulic supplied from operational hyd. pumps of superstructure is available instead.

RAVEL AND STEERING:

A bi-directional, shoe-in type axial piston hydraulic motor bolt-couples drive sprocket thru 3-stage planetary reduction gear unit outer case at each crawler side frame end for travel and steer. Straight-line travel (forward or reverse), pivot or differential turns, and counter-rotation for spin turns available.

Brake — Spring-applied, hydraulically released multiple wet-disc type automatic brake; located within hydraulic motor. Brakes automatically set when travel levers are in neutral or when engine is shut down.

Travel speed — 1.2/0.8km/hr. (based on flat, level and firm supporting surface, and under the conditions that no load must be applied and front-end att. must be the 15.25m basic boom only).

Gradeability — 30% (17°) permissible based on basic machine without front-end attachment.

designed, and available for keeping non free-fall operation during operation when it is necessary. Provided with key for switch on-off control.

HOOK OVER-HOIST LIMITING DEVICE:

Limit switch type. Available to prevent hook over-hoisting with functions of automatic drum braking with hydraulic lock, and warnings by red lamp and annunciating alarm.

BOOM OVER-HOIST AND -LOWERING LIMITING DEVICE:

Available in two kinds of devices; one is limit switch located on a part of boom foot for preventing boom over-hoisting, and the other is the safety function of the SML-10 available to automatically prevent boom over-hoisting and -lowering with the functions of automatic drum braking with hydraulic lock, and warnings by red lamp and annunciating alarm. Further boom protection from rapid boom over-hoist by hook over-hoist motion under mal-function of hook over-hoist limiting device is available as one of functions of the SML-10.

BOOM BACKSTOPS:

Dual; telescopic design with spring buffers.

DUAL BOOM OVER-HOIST LIMITING DEVICE:

Additional limit switch located on boom backstops; this is as a further safety device for redundant boom protection.

SWING LOCK:

Mechanically operated drop pin; available to firmly lock superstructure in four positions of facing front or rear or left or right to undercarriage.

DRUM LOCKS:

Power hydraulically operated pawl lock is available on front, rear and boom hoist drum with an automatic locking device as std. while electrically controlled pawl locks is designed on front and rear main drums i/o automatic in case that free-fall function is required.

BOOM ANGLE INDICATOR:

Pendulum type; mounted on right-hand side of bottom section of crane main boom.

HOOK LATCH:

Provided on every kinds of hook to prevent out of place of cable from hook.

LEVEL GAUGE:

Bubble type; located on operator's cab floor and a part of undercarriage.

LEVER LOCKS:

Provided on all control levers (except swing lever) to lock levers in neutral.

SWING ALARM:

This is by buzzer, and flasher lamps located on both sides of machinery cab.

Safety Devices

SML-10 LOAD MOMENT LIMITER:

This is a fully computerized total safe operation control system, and automatic over-load preventing system as standard equipment.

Construction (standard version) — Comprises (1) load detecting device, (2) boom angle detector, (3) amplifier, and (4) display panel with computerized Micro processing Unit (M.P.U).

Functions — This system functions that if a lifting load reaches a 90% of the rated one specified in the crane capacity chart, an annunciating pre-warning (Approaching Limit) is given; if it is an 100%, a warning is given by red lamp, and annunciating warning (Approaching Limit), and all peril side motions are automatically stopped. The machine, however, can be operated in safety side motions.

Display panel design — The SML-10 is designed to be able to input the operating conditions/data by setting keys on LCD 1, and to indicate the present lifting conditions/data like "lifting load", "rated load", "working radius" "boom angle", and so forth on LCD 2 thru LCD 5. Also, the LCD 1 indicates "engine rpm", "load ratio" and "lifting height (opt.)". In addition, the LCD 1 indicates letter messages when the machine becomes abnormal.

NON FREE-FALL OPERATION SWITCH:

Optional extra; this is standardized when opt. free-fall function on two main drums is

ANNUNCIATING ALARMS:

This is one of functions of the SML-10; provided with ten and some kinds of the alarm like "Approaching Limit".

SPEED SLOWDOWN DEVICE:

This is for speed slowdown of hoisting and lowering motions of crane main boom which are available just before automatic stopping to prevent a shock.

SWING BRAKE LAMP:

Provided on operator's cab instrument panel; this is available to confirm whether or not swing brake is applied.

SIGNAL HORN:

Available as warning just before every kinds of motions from operator.

FOOL PROOF SHUT-OFF SYSTEM:

Located in the cab exit; this is available to automatically deactives and locks hydraulic system.

TRAVEL ALARM:

Buzzer warns when travel motion is initiated.

ENGINE MONITORING LAMPS:

Available for checking engine operating conditions like battery charge, engine oil pressure, radiator coolant level, oil filter clogging, air filter clogging, and battery electrolyte amount.

EMERGENCY MACHINE STOP BUTTONS:

Two; each located nearby front main and boom hoist drums. Available when it is necessary to stop all machine motion.

REAR VIEW MIRRORS:

Two each provided on front-left and -right corners of super-structure.

THREE COLOR PERCENTAGE INDICATOR:

Optional extra; this is with three colours of Green, Yellow and Red. Each colour indicates the load percentage to rated capacity; Green shows less than 90% as safety, Yellow shows 90 to 99% as marginal, and Red shows over 100% as over-loading. As further function, Red lamp comes on automatically when operator cuts off safety device switch absent-mindedly.

LIFTING HEIGHT METER:

Optional extra; available to indicate lifting height above ground or depth below ground on display "LCD 1" of SML-10 Load Moment Limiter display panel. Also, hook hoisting speed slowdown function is available just before automatic stopping at a desired height under hook height setting before operation.

MICROPHONE & LOUD-SPEAKER:

Optional extra; this is for operator's convenience for loud speaking.

ANNUNCIATING SWING ALARM:

Optional extra; this is additional alarm for swing motion with a caution voice of "now swing, keep clear please!".

ANNUNCIATING TRAVEL ALARM:

Optional extra; this is additional alarm for travel motion with a caution voice of "now travel, keep clear please!".

DRUM LIGHT & MIRROR:

Optional extra; these are available for checking rope winding onto front and/or rear drum(s).

AUX. CRANE HOOK OVER-HOIST LIMITING DEVICE:

Optional extra; this is available for auxiliary crane hoist with optional aux. short jib and/or fly jib. Performs the same function as that of "Hook over-hoist limiting device" mentioned before.

Liftcrane 250 metric tons

CRANE BOOM:

Lattice construction, round tubular main chords, alloy, hi-ten steel, with bracing of round steel tubing.

Boom connections	In-line pin connections at 2.10m deep and 2.10m wide for heavy-duty booms, and 1.55m deep 1.55m wide for light-duty booms.
Basic boom	Two-piece, 15.25m basic length; 7.60m heavy-duty bottom and 7.60m heavy-duty tapered top boom.
Boom head machinery	Five head sheaves and two guide sheaves mounted on anti-friction bearings.
Five-hanger sheave block	Optional extra; pinned to boom head shaft. Five sheaves each mounted on anti-friction bearings. Required when lifting load exceeds 145ton, and available up to 250ton load.
Three-hanger sheave block	Optional extra; pinned to boom head shaft. Three sheaves each mounted on anti-friction bearings. Required when lifting load exceeds 145ton, and available up to 200ton load.
Heavy-duty boom extensions	Optional extra; available in 3.05m, 6.10m and 9.15m with pendants.
Tapered boom extensions	Optional extra; available in 4.55m with pendants.
Light-duty boom extensions	Optional extra; available in 3.05m, 6.10m and 9.15m length with pendants.
Light-duty tapered top boom	Optional extra; available in 9.15m with pendants.
Maximum boom length	88.40m (under combination of heavy-duty and light-duty boom extensions). 73.15m (under combination of heavy-duty boom extensions only).

FLY JIB:

Optional extra; lattice construction, round tubular main chords, alloy, hi-ten steel, with bracing of round steel tubing having in-line pin connections at 1.0m deep and 1.0m wide, and jib head machinery with single sheave mounted on anti-friction bearings. Provided with jib strut, jib backstops, and jib/boom guylines pendants. Mounted on 7.60m heavy duty tapered crane top section, and available for light load lifting operation with less than 25ton with two part or single part hoist line.

Basic fly jib	Two-piece, 12.20m basic length; 6.10m bottom and top sections.
Fly jib extensions	Available in 6.10m length with pendants.
Maximum fly jib length	36.55m.
Boom plus fly jib length	Max. 73.15m+36.55m.

AUXILIARY SHORT JIB:

Optional extra; all-welded construction having single sheave head machinery. Pinned to 7.60m heavy-duty tapered top boom or 9.15m light-duty tapered top boom.

HOOK BLOCKS:

250/145t, five sheaves plus 5-hanger sheave block with duplex type hook	Optional extra.
200/145t, five sheaves plus 3-hanger sheave block with duplex type hook	Optional extra.
145t, five sheaves with duplex type hook	Optional extra.
80t, three sheaves	Optional extra.
35/25t, one sheave	Optional extra.
13.5t, ball hook	Optional extra.

Notes: An 145t hook block is each available from 250t/200t hook block by dismantling a 5/3-hanger sheave block.

BAIL AND BRIDLE:

All-welded construction; provided with larger sheaves of a 21.4 D/d ratio on both bail and bridle for 2x8-part boom hoist rope reeving. Bail pinned to A-frame gantry, and bridle suspended between a 2x8-part boom hoist rope and pendant ropes connecting to tip of 7.60m tapered crane top section.

DRUM DATA:

Drum	Root dia.	Type	Line speed (Hoisting, Lowering)	Cable	Max. line pull
Front (main crane hoist) (towercrane hoist) (h/grab crown holding via hook) (c/bucket holding) (MHL/MEH bucket hoist)	576mm	Parallel grooved	120 ~ 2mpm	28mm	245kN (25.0ton)
Rear (aux. crane hoist) (tower jib hoist) (h/grab holding & closing) (c/bucket closing) (MHL/MEH bucket hoist)	576mm	Parallel grooved	120 ~ 2mpm *51 ~ 2mpm	28mm	245kN (25.0ton)
Boom hoist	504mm	Parallel grooved	2 x (24 ~ 1.0) mpm	22.4mm	165kN (16.9ton) x 2

Notes:

- Line speed is based on drum first layer and rated engine rpm with no load.
- Hoisting line speed varies under load and operating conditions.
- The figures with asterisk mark (*) indicate the rope line speed as applicable to tower jib hoist when luffing towercrane application

HOIST REEVING:

(ton)

hook \ No. of partline	20	16	14	12	10	8	7	6	5	4	3	2	1
250t	250.0	231.0	206.0	180.0	145.0	125.0	—	95.0	—	65.0	—	33.0	—
200t	—	—	200.0	180.0	145.0	125.0	—	95.0	—	65.0	—	33.0	—
145t	—	—	—	—	145.0	125.0	—	95.0	—	65.0	—	33.0	—
80t	—	—	—	—	—	—	—	—	80.0	65.0	49.0	33.0	13.5
35/25t	—	—	—	—	—	—	—	—	—	—	35.0	25.0	13.5
13.5t	—	—	—	—	—	—	—	—	—	—	—	—	13.5

CABLES:

- Front drumP-S (19)+39×P-7, non-spin type, 28mm dia./410m long, breaking load 755kN (77.0t).
- Rear drum.....Optional extra P.S (19)+39×P-7, non-spin type, 28mm dia., breaking load 755kN (77.0t). Following cable lengths are recommended.
Fly jib application350m.
Aux. shart jib application180m.
- Boom hoist drumXP rope with construction of IWRC 6×P·WS (31), 22.4mm dia./310m long, breaking load 417kN (42.5t).

WORKING WEIGHT & GROUND PRESSURE:

Shoe width	Weight	Pressure
1,120mm	203.0t	109kPa <1.11kg/cm²>

Note: Working weights shown above are respectively with 15.25m basic boom, 86.3ton counterweight, 14.0ton carbody weight, and optional 250ton hook block.

Liftcrane Capacities

■w/7.60m Tapered Crane Heavy Top Section

Boom length (m) Working radius (m)	15.25	18.30	21.35	24.40	27.45	30.50	33.50	36.55	39.60	42.65	45.70	48.75	51.80	54.85	57.90	60.95	64.00	67.05	70.10	73.15	
4.6	250.0																				
5.0	230.7	220.4/5.2	198.4/5.7																		
6.0	189.4	189.2	189.0	180.0/6.2	167.2/6.8																
7.0	163.6	163.4	163.2	162.9	162.6	145.0/7.3	139.0/7.8														
8.0	143.8	143.6	143.5	143.2	142.9	143.2	138.2	125.0/8.3	115.1/8.9												
9.0	128.2	128.0	127.9	127.6	127.3	127.6	127.3	123.8	114.8	105.2/9.4	95.0/9.9										
10.0	115.6	115.4	115.3	115.0	114.7	115.0	114.7	114.5	112.0	103.8	89.9	87.4/10.5	80.2/11.0	80.2/11.0							
12.0	89.6	89.5	89.3	89.2	89.0	89.5	89.3	89.4	89.2	88.9	89.9	84.8	78.7	73.0	67.9	62.1/12.6	53.7/13.1	52.9/13.6			
14.0	71.3	72.0	71.8	71.7	71.4	71.9	71.7	71.7	71.5	71.2	71.1	71.1	71.6	70.5	65.6	60.7	56.5	52.5	48.3/14.2	44.2/14.7	
16.0	63.0/14.8	60.1	59.8	59.6	59.3	59.8	59.5	59.6	59.4	59.1	58.9	58.9	58.6	58.4	59.0	58.8	54.8	51.0	47.0	43.0	
18.0		53.3/17.5	51.0	50.8	50.5	51.0	50.7	50.7	50.5	50.2	50.1	50.0	49.7	49.5	49.5	49.2	49.7	49.4	43.9	39.6	
20.0			44.4	44.2	43.8	44.3	44.0	44.0	43.8	43.4	43.3	43.2	42.9	42.7	42.7	42.4	42.3	42.2	40.6	36.6	
22.0			44.1/20.1	38.9	38.6	39.0	38.7	38.7	38.5	38.1	38.0	37.9	37.6	37.4	37.3	37.0	37.0	36.8	36.5	33.9	
24.0				37.3/22.7	34.4	34.7	34.4	34.4	34.2	33.8	33.7	33.6	33.2	33.1	33.0	32.7	32.6	32.4	32.1	31.6	
26.0					31.9/25.4	31.3	30.9	30.9	30.6	30.3	30.1	30.0	29.7	29.5	29.4	29.1	29.1	28.9	28.5	28.5	
28.0						28.3	28.0	27.9	27.7	27.3	27.2	27.1	26.7	26.5	26.5	26.1	26.1	25.9	25.5	25.5	
30.0							25.5	25.4	25.2	24.8	24.6	24.5	24.2	24.0	23.9	23.6	23.5	23.3	23.0	23.0	
32.0							24.7/30.7	23.3	23.0	22.6	22.5	22.4	22.0	21.8	21.7	21.4	21.3	21.1	20.8	20.8	
34.0								22.0/33.3	21.2	20.8	20.6	20.5	20.1	19.9	19.8	19.5	19.4	19.2	18.9	18.8	
36.0									19.6/35.9	19.1	18.9	18.8	18.4	18.3	18.2	17.8	17.7	17.5	17.2	17.2	
38.0										17.7	17.5	17.4	17.0	16.8	16.7	16.3	16.3	16.0	15.7	15.7	
40.0										17.3/38.6	16.2	16.1	15.7	15.5	15.4	15.0	14.9	14.7	14.4	14.3	
42.0											15.5/41.2	14.9	14.5	14.3	14.2	13.8	13.8	13.5	13.2	13.1	
44.0												13.9/43.9	13.5	13.3	13.2	12.8	12.7	12.5	12.1	12.1	
46.0													12.5	12.3	12.2	11.8	11.7	11.5	11.2	11.1	
48.0													12.3/46.5	11.5	11.3	11.0	10.9	10.6	10.3	10.2	
50.0														11.1/49.1	10.6	10.2	10.1	9.8	9.5	9.4	
52.0															9.9/51.8	9.5	9.3	9.1	8.7	8.7	
54.0																8.8	8.7	8.4	8.0	7.9	
56.0																8.7/54.4	8.1	7.8	7.3	7.2	
58.0																	7.7/57.1	7.1	6.7	6.5	
60.0																		6.6/59.7	6.1	5.9	
62.0																			5.5	5.3	
64.0																				5.4/62.3	4.6
65.0																					4.6

(EC403023)

■w/9.15m Tapered Crane Light Top Section

Boom length (m) Working radius (m)	73.15	76.20	79.25	82.30	85.35	88.40
14.0	37.5/14.5	34.5/15.0	32.7/15.5			
16.0	35.9	33.5	32.1	31.5/16.1	25.0/16.5	25.0/17.0
18.0	34.3	31.7	30.4	29.7	25.0	25.0
20.0	32.9	30.2	28.9	28.2	25.0	24.1
22.0	31.6	28.9	27.5	26.9	25.0	23.2
24.0	30.2	27.7	26.3	25.7	24.2	22.1
26.0	28.5	26.2	25.3	24.6	23.1	20.9
28.0	26.0	24.9	24.4	23.5	22.1	20.0
30.0	23.8	23.4	23.1	22.3	21.0	18.9
32.0	21.6	21.7	21.6	20.9	19.9	17.9
34.0	19.8	19.8	19.7	19.7	18.7	16.9
36.0	18.2	18.1	18.1	18.1	17.6	15.9
38.0	16.7	16.6	16.6	16.6	16.3	14.8
40.0	15.3	15.3	15.2	15.2	15.2	13.9
42.0	14.2	14.1	14.1	14.1	14.0	13.1
44.0	13.1	13.0	13.0	13.0	12.9	12.3
46.0	12.1	12.1	12.0	12.0	12.0	11.6
48.0	11.2	11.2	11.1	11.1	11.1	10.9
50.0	10.4	10.4	10.3	10.3	10.3	10.2
52.0	9.7	9.7	9.6	9.6	9.5	9.5
54.0	9.0	9.0	8.9	8.9	8.9	8.9
56.0	8.4	8.4	8.3	8.3	8.3	8.3
58.0	7.8	7.8	7.7	7.7	7.7	7.7
60.0	7.3	7.2	7.1	7.1	7.1	7.1
62.0	6.7	6.6	6.6	6.6	6.6	6.6
64.0	6.2	6.1	6.0	6.0	6.0	6.0
66.0	6.0/64.9	5.6	5.6	5.6	5.6	5.6
68.0		5.3/67.5	5.1	5.1	5.1	5.1
70.0			4.7	4.7	4.7	4.7
72.0			4.6/70.2	4.3	4.3	4.3
74.0				4.1/72.8	3.9	3.9
76.0					3.7/74.8	3.5
77.4						3.2

(EC403023)

Notes — Liftcrane capacities

1. Capacities included in this chart are the maximum allowable, and are based on machine standing level on firm supporting surface under ideal job conditions.
2. Capacities are in metric tons, and are not more than 78% of minimum tipping loads except the figures surrounded by bold lines which are based on other factor of machine structural strength limitation.
3. Capacities are based on freely suspended loads and make no allowance for such factors as the effect of wind, sudden stopping of loads, supporting surface conditions, and operating speeds. Operator must reduce load ratings to take such conditions into account. Deduction from rated capacities must be made for weight of hook block, weighted ball/hook, sling, spreader bar, or other suspended gear.
Hook block weight is as follows:
250t.....3.4ton 200t3.0ton 145t2.5ton
80t.....1.4ton 35/25t0.9ton 13.5t0.6ton
4. All capacities are rated for 360° swing.
5. Least stable rated condition is over the side.
6. An 86.3ton counterweight and 1.7ton auxiliary weight, and 14.0ton carbody weight are required for all capacities on this chart.
7. Attachment must be erected and lowered over the ends of the crawler mounting.
8. Main boom length must not exceed 88.40m.
Maximum boom length when mounting auxiliary short jib is 85.35m.
9. Capacities when handling load off main boom head sheaves in case of mounting auxiliary short jib on top of boom are detailed; if required, please consult us or nearest distributor.
10. Boom combination shall be in accordance with manufacture's standard described here in "Boom Combination Diagram".

**SCX2500 AUXILIARY SHORT JIB CAPACITIES:
Max. 13.5ton**

Note: Jib capacities is almost equal to the figures made by the deduction of an 600kg from the liftcrane capacities for boom length up to 85.35m unless restricted by the maximum jib capacity shown above. As to the details, please consult us or nearest distributor.

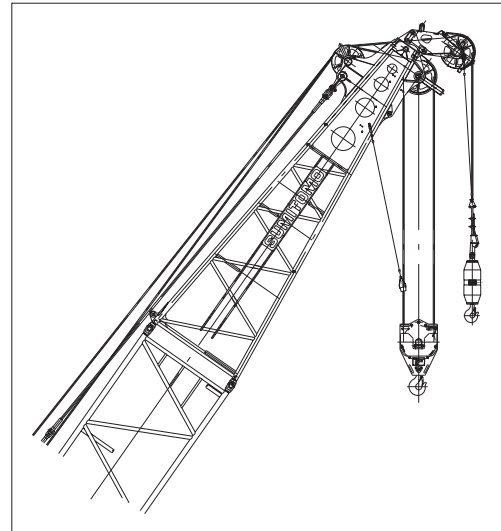

Auxiliary short jib (Option)

Liftcrane Working Ranges

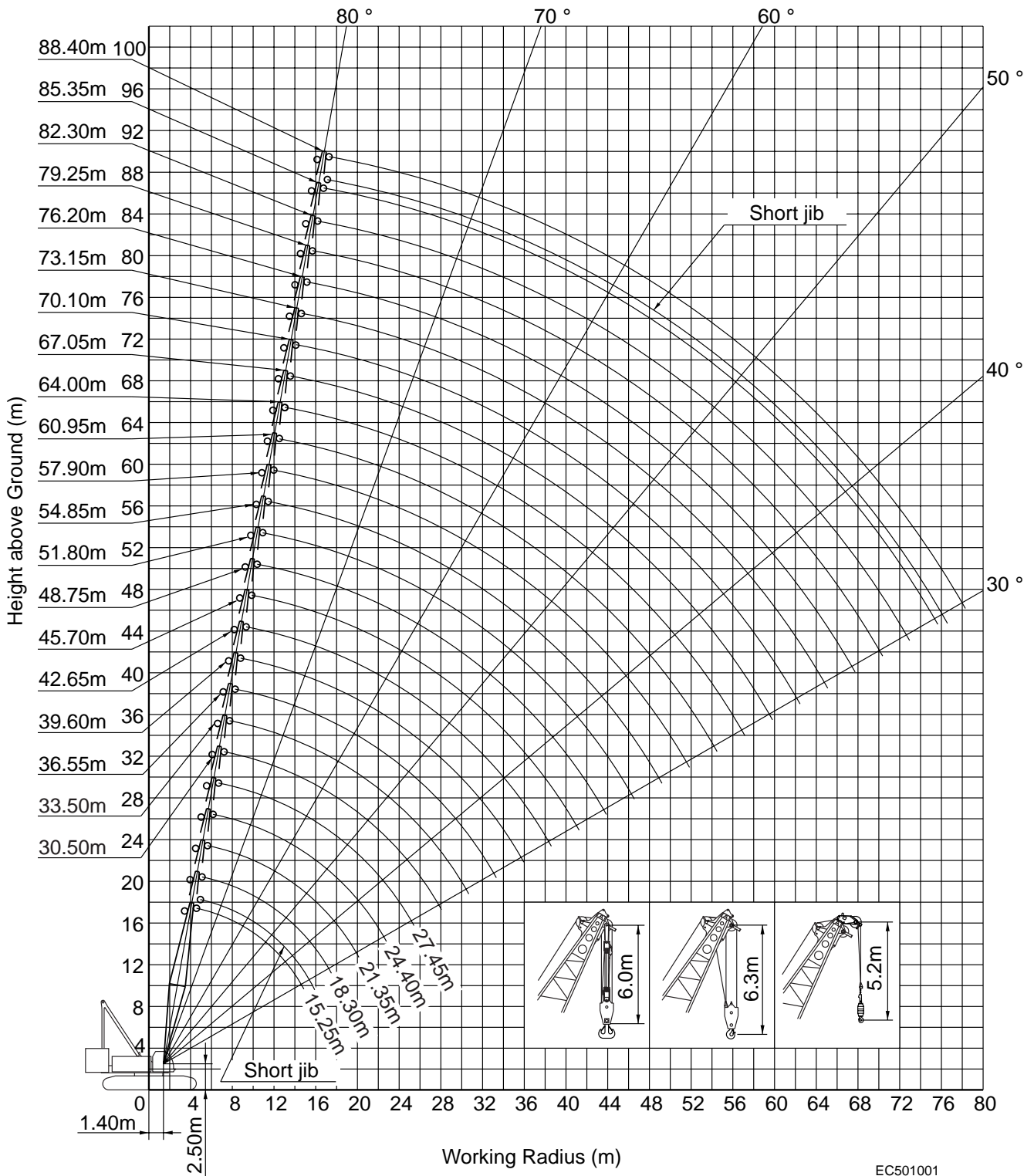

EC501001

Note: This diagram just shows working ranges under 88.40m boom length as max. without fly jib.

Boom Combination Diagram

Boom length (m)	Boom combination
15.25	
18.30	
21.35	
24.40	
27.45	
30.50	
33.50	
36.55	
39.60	
42.65	
45.70	
48.75	
51.80	
54.85	
57.90	
60.95	
64.00	
67.05	
70.10	
73.15	
76.20	
79.25	
82.30	
85.35	
88.40	

Note: Whenever fly jib is attached on main boom ranging all the way from 45.70m thru 73.15m, HEAVY-DUTY TAPERED TOP SECTION of 7.60m is required. And, in the case that main boom length of 73.15m as available as the longest is required, a 57.95m long heavy-duty boom extension in total is correspondingly necessary, and its configuration shall be 2 pce. of 3.05m, 1 pc. of 6.10m and 5 pce. of 9.15m as an ideal one.

Note:

The meanings of figures and symbols shown above are as follows:

- : 7.60m heavy-duty bottom section
- : 7.60m heavy-duty tapered top section
- : 9.15m light-duty tapered top section
- : 9.15m heavy-duty boom extension
- : 6.10m heavy-duty boom extension
- : 3.05m heavy-duty boom extension
- : 4.55m tapered boom extension
- : 9.15m light-duty boom extension
- : 6.10m light-duty boom extension
- : 3.05m light-duty boom extension
- * : Midpoint link installing position; it is required to install midpoint link when boom length is 73.15m and over.

Standard and Optional Equipment

	Standard equipment	Optional equipment
Superstructure	<ul style="list-style-type: none"> ● Mitsubishi 6D24-TL diesel engine with a 235kW <320ps> rated output; ● Hydraulic system with three variable displacement axial piston pumps and one fixed displacement duplicate tandem gear pump; provided with an independent oil cooler; ● Control system with one each of duplicate and triplicate tandem valves and pilot-operated arm chair single axis control levers; ● Motorcycle type "SC" controller (easy-precise-minute engine rpm and hyd. pump oil flow control device); ● Front and rear main operating drum winches of 25ton line pull with 576mm dia. drum lagging driven by independent variable hyd. motor with independent hyd. circuit; each provided with automatic brake; ● Boom hoist mechanism driven by hyd. motor with automatic brake; ● Swing mechanism with turntable bearing; driven by two hyd. motors w/spring-applied, power hydraulically released multiple wet-disc brake; ● Power hydraulically retractable A-frame gantry; ● All new stamped, automotive type, full-vision operator's cab with large curved front window; provided with an arrangement of armchair operator control station and instrument panel; ● 86.3ton counterweight; ● 1.7ton auxiliary weight; ● Machinery cab with hinged doors; ● 24-volt electrical system with two 12-volt batteries; ● Lighting system: <ul style="list-style-type: none"> • Two 70W working lights; • One 10W interior cab light; ● Accessories: <ul style="list-style-type: none"> • AM/FM radio w/clock; • Engine hourmeter; • Engine tachometer; • Fuel gauge; • Thermometer; • Hyd. oil temp. gauge; • Pilot line pressure gauge; • Foot throttle; • Intermittent dual window shield wipers with washers; • Cigar lighter; • Ash tray; • Book holder; • Sunvisor; • Sunshade; • Cup Holder; • Non-skid surfaces; • Cab front step; • Cab floor mat; • Superstructure under-cover. ● Std. spare parts and tools. 	<ul style="list-style-type: none"> ● Hydraulic tagline winder; ● Anemometer; recommended for luffing tower crane operation; ● Drum rollers; available on front/rear main; ● Stone guard; this is for operator's cab; ● Fire extinguisher; ● Catwalks, along both sides of machinery cab; ● Built-in type full air-conditioning; ● Re-fuel pump; ● Heater; ● External contracting band brakes and clutches; required instead of standardized automatic brake in case that a true gravity free-fall function is necessary on front/rear main drums.

	Standard equipment	Optional equipment
Undercarriage	<ul style="list-style-type: none"> ● 6,400mm gauge by 9,045mm long crawler lower with removable crawler side frames; ● Crawler drive units with shoe-in type traction motor with wet-disc type automatic brakes; ● 1,120mm wide track shoes; ● Manual track tension adjusting devices; ● Carbody jack-up device w/4-vertical hyd. jack-up cylinder and remote control unit; ● 14ton carbody weight; ● Lifetime lubricated track components; ● Crawler side steps; ● Joint cylinders. 	<ul style="list-style-type: none"> ● Automatic track tension adjusting device, i/o manual one as std.
Liftcrane Att.	<ul style="list-style-type: none"> ● 15.25m basic crane boom; 7.60m bottom section and 7.60m tapered crane top section w/five head sheaves, and two guide sheaves; provided with boom foot pin removal cylinders; ● Bail and bridle assemblies; ● Main crane hoist cable; 28mm dia./410m long; ● Boom hoist cable; 22.4mm dia./310m long; 	<ul style="list-style-type: none"> ● 3.05m heavy-duty boom extension; ● 6.10m heavy-duty boom extension; ● 9.15m heavy-duty boom extension; ● 4.55m tapered boom extension; ● 3.05m light-duty boom extension; ● 6.10m light-duty boom extension; ● 9.15m light-duty boom extension; ● 9.15m light-duty tapered top boom; ● 12.20m basic fly jib; 6.10m bottom and top sections with jib strut and boom/jib quylene pendants; ● 6.10m fly jib extension; ● Auxiliary short jib; ● 250/145t with a 5-hanger sheave block; ● 200/145t with a 3-hanger sheave block; ● 145t hook block; ● 80t hook block; ● 35/25t hook block; ● 13.5t ball hook; ● Five-hanger sheave block; required together with 250t hook block when lifting load exceeds 145ton, and available up to 250ton load; ● Three-hanger sheave block; required together with 200t hook block when lifting load exceeds 145ton, and available up to 200ton load; ● Aux. crane hoist cable, 28mm dia./300m long; available for fly jib application; ● Aux. crane hoist cable, 28mm/180m long; available for aux. shart jib application; ● Boom skywalk; available for all sections of lificrane main boom.

	Standard equipment	Optional equipment
Luffing Towercrane Att.		<p style="text-align: center;">—To be advised later —</p>
Safety Devices	<ul style="list-style-type: none"> ● SML-10 Load Moment Limiter; this is a computerized automatic over-load preventing system with an all-machine-control purpose computer; ● Ten and some kinds of annunciating alarms; ● Main and aux. drum pawl locks; ● Boom hoist drum pawl lock; ● Swing lock; ● Swing alarm; ● Hook over-hoist limiting device; ● Boom over-hoist and -lowering limiting device; ● Dual boom over-hoist limiting device; ● Boom backstops; ● Speed slowdown device; ● Boom angle indicator; ● Level gauge; fitted on floor of operator's cab and a poat of undercarriage; ● Swing brake lamp; ● Signal horn; ● Travel alarm; ● Hook latch; ● Control lever locks; ● Fool proof shut-off system; ● Engine monitoring lamps; ● Rear view mirrors; ● Emergency machine stop buttons; 	<ul style="list-style-type: none"> ● Annunciating swing alarm; ● Annunciating travel alarm; ● Aux. hook over-hoist limiting device; ● Lifting height meter; ● Three color percentage indicator; ● Microphone & loud-speaker; ● Drum light & mirror.

Hitachi Sumitomo Heavy Industries Construction Crane Co., Ltd.

12-14, Ueno 7-chome, Taito-ku, Tokyo 110-0005, Japan

Phone: 81-3-3845-1387 Facsimile: 81-3-3845-1394

- We are constantly improving our products and therefore reserve the right to change designs and specifications without notice.
- Units in this specification are shown under International System of Units; the figures in parenthesis are under Gravitational System of Units as old one.

Address Inquires to:



SCX2500

SUPPLEMENTARY

FLY JIB CAPACITIES

These fly jib capacities are under the conditions of boom length from 45.70m through 73.15m.

LIFTCRANE CAPACITIES with fly jib on top of main boom

These capacity charts show the figures when handling load off main boom head sheaves in a case of mounting fly jib on top of main boom.

Fly Jib Capacities

■ w/45.70m Boom

Fly jib length (m)	12.20				18.30				24.40		30.50		36.55	
Fly jib offset angle (°)	10		30		10		30	10	30	10	30	10	30	
No. of part line Working radius (m)	2-part	1-part	2-part	1-part	2-part	1-part	1-part	1-part	1-part	1-part	1-part	1-part	1-part	
14.0	25.0/14.2	13.5/14.5												
16.0	25.0	13.5	14.9/17.2	13.5/17.6	19.5/16.8	13.5/17.1								
18.0	25.0	13.5	14.7	13.5	19.1	13.5		12.9/19.2						
20.0	25.0	13.5	14.4	13.5	18.6	13.5	10.6/21.6	12.8		7.0/20.8		4.9/21.9		
22.0	24.1	13.5	14.1	13.5	18.0	13.5	10.5	12.5		6.9		4.8		
24.0	23.1	13.5	13.8	13.5	17.5	13.5	10.3	12.3	8.6/25.1	6.8		4.8		
26.0	22.1	13.5	13.5	13.5	16.9	13.5	10.1	12.1	8.5	6.6		4.7		
28.0	21.2	13.5	13.2	13.2	16.4	13.5	9.8	11.9	8.3	6.5	5.4/28.2	4.6		
30.0	20.2	13.5	12.9	12.9	15.9	13.5	9.6	11.7	8.2	6.4	5.3	4.5	3.1/30.8	
32.0	19.3	13.5	12.6	12.6	15.3	13.5	9.4	11.4	8.0	6.3	5.2	4.5	3.0	
34.0	18.3	13.5	12.3	12.3	14.8	13.5	9.2	11.2	7.8	6.2	5.2	4.4	3.0	
36.0	17.3	13.5	12.0	12.0	14.2	13.5	9.0	11.0	7.7	6.0	5.1	4.3	3.0	
38.0	16.4	13.5	11.7	11.7	13.7	13.5	8.7	10.8	7.5	5.9	5.0	4.2	3.0	
40.0	15.4	13.5	11.4	11.4	13.1	13.1	8.5	10.6	7.3	5.8	5.0	4.1	3.0	
42.0	14.4	13.5	11.1	11.1	12.6	12.6	8.3	10.4	7.2	5.7	4.9	4.1	2.9	
44.0	13.5	13.5	10.8	10.8	12.1	12.1	8.1	10.1	7.0	5.5	4.8	4.0	2.9	
46.0	12.5	12.5	10.5	10.5	11.5	11.5	7.9	9.9	6.9	5.4	4.8	3.9	2.9	
48.0	11.6	11.6	10.2	10.2	11.0	11.0	7.6	9.7	6.7	5.3	4.7	3.8	2.9	
50.0	10.6	10.6	9.9	9.9	10.4	10.4	7.4	9.5	6.5	5.2	4.7	3.8	2.8	
52.0	9.6	9.6	9.6	9.6	9.9	9.9	7.2	9.3	6.4	5.1	4.6	3.7	2.8	
54.0	9.6/52.4	9.6/53.2	9.5/52.9	9.5/53.7	9.4	9.4	7.0	9.0	6.2	4.9	4.5	3.6	2.8	
56.0					8.8	8.8	6.8	8.8	6.1	4.8	4.5	3.5	2.8	
58.0					8.3	8.3	6.5	8.6	5.9	4.7	4.4	3.4	2.8	
60.0					8.3/58.3	8.3/59.1	6.4/59.8	8.4	5.7	4.6	4.3	3.4	2.7	
62.0								8.1	5.6	4.5	4.3	3.3	2.7	
64.0								7.6	5.4	4.3	4.2	3.2	2.7	
66.0								7.4/64.8	5.3/65.9	4.2	4.1	3.1	2.7	
68.0										4.1	4.1	3.1	2.7	
70.0										4.0	4.0	3.0	2.6	
72.0										4.0/70.4	4.0	2.9	2.6	
74.0												2.8	2.6	
76.0												2.8/75.7	2.6	
78.0													2.6	

(EC401057)

■ w/48.75m Boom

Fly jib length (m)	12.20				18.30				24.40		30.50		36.55	
Fly jib offset angle (°)	10		30		10		30	10	30	10	30	10	30	
No. of part line Working radius (m)	2-part	1-part	2-part	1-part	2-part	1-part	1-part	1-part	1-part	1-part	1-part	1-part	1-part	
14.0	25.0/14.8	13.5/15.0												
16.0	25.0	13.5	14.9/17.7		19.5/17.4	13.5/17.6								
18.0	25.0	13.5	14.8	13.5/18.2	19.2	13.5		12.9/19.7						
20.0	25.0	13.5	14.5	13.5	18.7	13.5		12.8		7.0/21.3				
22.0	24.5	13.5	14.2	13.5	18.2	13.5	10.6/22.1	12.6		6.9		4.9/22.4		
24.0	23.6	13.5	13.9	13.5	17.7	13.5	10.4	12.4	8.6/25.6	6.8		4.8		
26.0	22.7	13.5	13.6	13.5	17.2	13.5	10.2	12.2	8.5	6.7		4.7		
28.0	21.8	13.5	13.4	13.4	16.7	13.5	9.9	12.0	8.4	6.6	5.4/28.7	4.6		
30.0	20.9	13.5	13.1	13.1	16.2	13.5	9.7	11.8	8.2	6.4	5.3	4.6	3.1/31.3	
32.0	19.9	13.5	12.8	12.8	15.6	13.5	9.5	11.6	8.1	6.3	5.2	4.5	3.0	
34.0	19.0	13.5	12.5	12.5	15.1	13.5	9.3	11.4	7.9	6.2	5.2	4.4	3.0	
36.0	18.1	13.5	12.2	12.2	14.6	13.5	9.1	11.2	7.8	6.1	5.1	4.3	3.0	
38.0	16.8	13.5	11.9	11.9	14.1	13.5	8.9	10.9	7.6	6.0	5.1	4.3	3.0	
40.0	15.5	13.5	11.6	11.6	13.6	13.5	8.7	10.7	7.5	5.9	5.0	4.2	3.0	
42.0	14.3	13.5	11.4	11.4	13.1	13.1	8.5	10.5	7.3	5.7	4.9	4.1	2.9	
44.0	13.3	13.3	11.1	11.1	12.6	12.6	8.3	10.3	7.1	5.6	4.9	4.0	2.9	
46.0	12.3	12.3	10.8	10.8	12.1	12.1	8.1	10.1	7.0	5.5	4.8	4.0	2.9	
48.0	11.5	11.5	10.5	10.5	11.5	11.5	7.9	9.9	6.8	5.4	4.8	3.9	2.9	
50.0	10.7	10.7	10.2	10.2	11.0	11.0	7.7	9.7	6.7	5.3	4.7	3.8	2.9	
52.0	9.9	9.9	9.9	9.9	10.3	10.3	7.4	9.5	6.5	5.2	4.6	3.7	2.8	
54.0	9.3	9.3	9.3	9.3	9.7	9.7	7.2	9.3	6.4	5.1	4.6	3.7	2.8	
56.0	9.0/55.1	8.9/55.8	8.9/55.6		8.9	9.0	7.0	9.1	6.2	4.9	4.5	3.6	2.8	
58.0				8.8/56.4	8.4	8.4	6.8	8.8	6.1	4.8	4.5	3.5	2.8	
60.0					7.9	7.9	6.6	8.4	5.9	4.7	4.4	3.4	2.8	
62.0					7.7/61.0	7.7/61.7	6.4	7.9	5.8	4.6	4.3	3.4	2.7	
64.0							6.4/62.5	7.4	5.6	4.5	4.3	3.3	2.7	
66.0								6.9	5.5	4.4	4.2	3.2	2.7	
68.0								6.6/67.5	5.3	4.2	4.2	3.1	2.7	
70.0									5.3/68.6	4.1	4.1	3.1	2.7	
72.0										4.0	4.0	3.0	2.6	
74.0										4.0/73.0	4.0	2.9	2.6	
76.0											4.0/74.6	2.8	2.6	
78.0												2.8	2.6	
80.0												2.8/78.4	2.6	
82.0													2.6/80.6	

(EC401057)

■ w/51.80m Boom

Fly jib length (m)	12.20				18.30				24.40		30.50		36.55	
Fly jib offset angle (°)	10		30		10		30	10	30	10	30	10	30	
No. of part line	2-part	1-part	2-part	1-part	2-part	1-part	1-part	1-part	1-part	1-part	1-part	1-part	1-part	
Working radius (m)														
14.0	25.0/15.3	13.5/15.6												
16.0	25.0	13.5			19.5/17.9									
18.0	25.0	13.5	14.9/18.2	13.5/18.7	19.4	13.5/18.2								
20.0	25.0	13.5	14.6	13.5	18.9	13.5		12.9/20.2		7.0/21.8				
22.0	24.9	13.5	14.3	13.5	18.4	13.5	10.6/22.7	12.7		6.9		4.9/22.9		
24.0	24.0	13.5	14.0	13.5	17.9	13.5	10.4	12.5		6.8		4.8		
26.0	23.1	13.5	13.8	13.5	17.4	13.5	10.2	12.3	8.6/26.2	6.7		4.7		
28.0	22.3	13.5	13.5	13.5	16.9	13.5	10.0	12.1	8.4	6.6	5.4/29.2	4.7		
30.0	21.4	13.5	13.2	13.2	16.4	13.5	9.8	11.9	8.3	6.5	5.3	4.6	3.1/31.8	
32.0	20.6	13.5	13.0	13.0	15.9	13.5	9.6	11.7	8.1	6.4	5.3	4.5	3.0	
34.0	19.6	13.5	12.7	12.7	15.5	13.5	9.4	11.5	8.0	6.3	5.2	4.5	3.0	
36.0	18.0	13.5	12.4	12.4	15.0	13.5	9.2	11.3	7.8	6.2	5.2	4.4	3.0	
38.0	16.5	13.5	12.2	12.2	14.5	13.5	9.0	11.1	7.7	6.1	5.1	4.3	3.0	
40.0	15.2	13.5	11.9	11.9	14.0	13.5	8.8	10.9	7.5	5.9	5.0	4.2	3.0	
42.0	14.0	13.5	11.6	11.6	13.5	13.5	8.6	10.7	7.4	5.8	5.0	4.2	3.0	
44.0	13.0	13.0	11.3	11.3	13.0	13.0	8.4	10.5	7.2	5.7	4.9	4.1	2.9	
46.0	12.0	12.0	11.1	11.1	12.5	12.5	8.2	10.3	7.1	5.6	4.9	4.0	2.9	
48.0	11.2	11.2	10.8	10.8	11.6	11.6	8.0	10.1	7.0	5.5	4.8	3.9	2.9	
50.0	10.4	10.4	10.5	10.5	10.8	10.8	7.8	9.9	6.8	5.4	4.7	3.9	2.9	
52.0	9.6	9.6	9.8	9.8	10.0	10.0	7.6	9.7	6.7	5.3	4.7	3.8	2.9	
54.0	9.0	9.0	9.1	9.1	9.4	9.4	7.4	9.5	6.5	5.2	4.6	3.7	2.8	
56.0	8.3	8.3	8.4	8.4	8.7	8.7	7.3	9.3	6.4	5.0	4.6	3.7	2.8	
58.0	7.9/57.7	7.9	7.8	7.8	8.1	8.1	7.1	8.7	6.2	4.9	4.5	3.6	2.8	
60.0		7.8/58.5	7.7/58.2	7.7/59.0	7.6	7.6	6.9	8.1	6.1	4.8	4.5	3.5	2.8	
62.0					7.1	7.1	6.7	7.6	5.9	4.7	4.4	3.4	2.8	
64.0					6.7/63.6	6.7	6.5	7.1	5.8	4.6	4.3	3.4	2.7	
66.0						6.7/64.4	6.4/65.1	6.6	5.6	4.5	4.3	3.3	2.7	
68.0								6.2	5.5	4.4	4.2	3.2	2.7	
70.0								5.7	5.3	4.3	4.2	3.1	2.7	
72.0								5.7/70.1	5.3/71.2	4.2	4.1	3.1	2.7	
74.0										4.0	4.0	3.0	2.6	
76.0										4.0/75.7	4.0	2.9	2.6	
78.0											4.0/77.3	2.9	2.6	
80.0												2.8	2.6	
82.0												2.8/81.0	2.6	
84.0													2.6/83.3	

(EC401057)

■ w/54.85m Boom

Fly jib length (m)	12.20				18.30				24.40		30.50		36.55	
Fly jib offset angle (°)	10		30		10		30	10	30	10	30	10	30	
No. of part line	2-part	1-part	2-part	1-part	2-part	1-part	1-part	1-part	1-part	1-part	1-part	1-part	1-part	
Working radius (m)														
14.0	25.0/15.8													
16.0	25.0	13.5/16.1												
18.0	25.0	13.5	14.9/18.8	13.5/19.2	19.5/18.4	13.5/18.7								
20.0	25.0	13.5	14.7	13.5	19.1	13.5		12.9/20.8						
22.0	25.0	13.5	14.4	13.5	18.6	13.5	10.6/23.2	12.7		7.0/22.4		4.9/23.4		
24.0	24.4	13.5	14.2	13.5	18.1	13.5	10.5	12.5		6.9		4.8		
26.0	23.6	13.5	13.9	13.5	17.6	13.5	10.3	12.3	8.6/26.7	6.8		4.8		
28.0	22.8	13.5	13.6	13.5	17.2	13.5	10.1	12.2	8.5	6.6	5.4/29.8	4.7		
30.0	22.0	13.5	13.4	13.4	16.7	13.5	9.9	12.0	8.3	6.5	5.3	4.6		
32.0	21.1	13.5	13.1	13.1	16.2	13.5	9.7	11.8	8.2	6.4	5.3	4.6	3.1/32.4	
34.0	19.4	13.5	12.9	12.9	15.8	13.5	9.5	11.6	8.0	6.3	5.2	4.5	3.0	
36.0	17.8	13.5	12.6	12.6	15.3	13.5	9.3	11.4	7.9	6.2	5.2	4.4	3.0	
38.0	16.3	13.5	12.4	12.4	14.8	13.5	9.2	11.2	7.8	6.1	5.1	4.3	3.0	
40.0	15.0	13.5	12.1	12.1	14.4	13.5	9.0	11.0	7.6	6.0	5.1	4.3	3.0	
42.0	13.8	13.5	11.8	11.8	13.9	13.5	8.8	10.8	7.5	5.9	5.0	4.2	3.0	
44.0	12.8	12.8	11.6	11.6	13.2	13.2	8.6	10.6	7.3	5.8	5.0	4.1	2.9	
46.0	11.8	11.8	11.3	11.3	12.3	12.3	8.4	10.4	7.2	5.7	4.9	4.1	2.9	
48.0	10.9	10.9	11.1	11.1	11.4	11.4	8.2	10.2	7.1	5.6	4.8	4.0	2.9	
50.0	10.2	10.2	10.3	10.3	10.6	10.6	8.0	10.0	6.9	5.5	4.8	3.9	2.9	
52.0	9.4	9.4	9.6	9.6	9.8	9.8	7.8	9.8	6.8	5.4	4.7	3.9	2.9	
54.0	8.7	8.7	8.9	8.9	9.1	9.1	7.6	9.7	6.6	5.3	4.7	3.8	2.8	
56.0	8.1	8.1	8.2	8.2	8.5	8.5	7.5	9.1	6.5	5.1	4.6	3.7	2.8	
58.0	7.5	7.5	7.6	7.6	7.9	7.9	7.3	8.5	6.4	5.0	4.6	3.6	2.8	
60.0	7.0	7.0	7.0	7.0	7.4	7.4	7.1	7.9	6.2	4.9	4.5	3.6	2.8	
62.0	6.9/60.4	6.9/61.1	6.8/60.8	6.8/61.6	6.9	6.9	6.9	7.4	6.1	4.8	4.5	3.5	2.8	
64.0					6.3	6.3	6.7	6.9	5.9	4.7	4.4	3.4	2.8	
66.0					5.8	5.8	6.2	6.4	5.8	4.6	4.3	3.4	2.7	
68.0					5.8/66.3	5.8/67.0	5.7/67.7	5.9	5.7	4.5	4.3	3.3	2.7	
70.0								5.5	5.5	4.4	4.2	3.2	2.7	
72.0								5.0	5.2	4.3	4.2	3.2	2.7	
74.0								4.9/72.7	4.7/73.8	4.2	4.1	3.1	2.7	
76.0										4.1	4.1	3.0	2.6	
78.0										4.0	4.0	2.9	2.6	
80.0										4.0/78.3	3.9/79.9	2.9	2.6	
82.0												2.8	2.6	
84.0												2.8/83.7	2.6	
86.0													2.6/85.9	

(EC401057)

■ w/57.90m Boom

Fly jib length (m)	12.20				18.30				24.40		30.50		36.55	
Fly jib offset angle (°)	10		30		10		30	10	30	10	30	10	30	
No. of part line	2-part	1-part	2-part	1-part	2-part	1-part	1-part	1-part	1-part	1-part	1-part	1-part	1-part	
Working radius (m)														
16.0	25.0/16.3	13.5/16.6												
18.0	25.0	13.5	14.9/19.3	13.5/19.8	19.5/18.9	13.5/19.2								
20.0	25.0	13.5	14.7	13.5	19.2	13.5			12.9/21.3					
22.0	25.0	13.5	14.5	13.5	18.7	13.5	10.6/23.7	12.8		7.0/22.9				
24.0	24.8	13.5	14.3	13.5	18.3	13.5	10.5	12.6		6.9			4.9	
26.0	24.0	13.5	14.0	13.5	17.8	13.5	10.3	12.4	8.6/27.2	6.8			4.8	
28.0	23.2	13.5	13.8	13.5	17.4	13.5	10.2	12.2	8.5	6.7			4.7	
30.0	22.4	13.5	13.5	13.5	16.9	13.5	10.0	12.0	8.4	6.6	5.4/30.3		4.6	
32.0	21.1	13.5	13.3	13.3	16.5	13.5	9.8	11.9	8.2	6.5	5.3	4.6	3.1/32.9	
34.0	19.2	13.5	13.0	13.0	16.0	13.5	9.6	11.7	8.1	6.4	5.3	4.5	3.0	
36.0	17.6	13.5	12.8	12.8	15.6	13.5	9.4	11.5	8.0	6.3	5.2	4.4	3.0	
38.0	16.1	13.5	12.5	12.5	15.1	13.5	9.3	11.3	7.8	6.2	5.1	4.4	3.0	
40.0	14.8	13.5	12.3	12.3	14.7	13.5	9.1	11.1	7.7	6.1	5.1	4.3	3.0	
42.0	13.6	13.5	12.1	12.1	14.1	13.5	8.9	10.9	7.6	6.0	5.0	4.2	3.0	
44.0	12.6	12.6	11.8	11.8	13.0	13.0	8.7	10.8	7.4	5.9	5.0	4.2	3.0	
46.0	11.6	11.6	11.6	11.6	12.0	12.0	8.5	10.6	7.3	5.8	4.9	4.1	2.9	
48.0	10.7	10.7	11.0	11.0	11.2	11.2	8.4	10.4	7.2	5.7	4.9	4.0	2.9	
50.0	9.9	9.9	10.2	10.2	10.4	10.4	8.2	10.2	7.0	5.6	4.8	4.0	2.9	
52.0	9.2	9.2	9.4	9.4	9.6	9.6	8.0	10.0	6.9	5.4	4.8	3.9	2.9	
54.0	8.5	8.5	8.7	8.7	8.9	8.9	7.8	9.5	6.8	5.3	4.7	3.8	2.9	
56.0	7.9	7.9	8.0	8.0	8.3	8.3	7.6	8.8	6.6	5.2	4.7	3.8	2.8	
58.0	7.3	7.3	7.4	7.4	7.7	7.7	7.5	8.2	6.5	5.1	4.6	3.7	2.8	
60.0	6.7	6.7	6.8	6.8	7.2	7.2	7.3	7.7	6.4	5.0	4.6	3.6	2.8	
62.0	6.1	6.1	6.2	6.2	6.6	6.6	7.1	7.2	6.2	4.9	4.5	3.6	2.8	
64.0	5.9/63.0	5.9/63.7	5.8/63.5	5.8	6.0	6.0	6.5	6.7	6.1	4.8	4.4	3.5	2.8	
66.0				5.8/64.3	5.5	5.5	5.9	6.1	6.0	4.7	4.4	3.4	2.8	
68.0					5.0	5.0	5.4	5.6	5.8	4.6	4.3	3.4	2.7	
70.0					4.9/68.9	4.9/69.6	4.9	5.2	5.5	4.5	4.3	3.3	2.7	
72.0							4.8/70.4	4.7	5.0	4.4	4.2	3.2	2.7	
74.0								4.3	4.5	4.3	4.2	3.2	2.7	
76.0								4.0/75.4	4.0	4.2	4.1	3.1	2.7	
78.0									3.9/76.5	3.8	4.1	3.0	2.6	
80.0										3.5	3.7	3.0	2.6	
82.0										3.3/80.9	3.3	2.9	2.6	
84.0											3.2/82.5	2.8	2.6	
86.0												2.7	2.6	
88.0												2.6/86.3	2.6	
90.0													2.5/88.5	

(EC401057)

■ w/60.95m Boom

Fly jib length (m)	12.20				18.30				24.40		30.50		36.55	
Fly jib offset angle (°)	10		30		10		30	10	30	10	30	10	30	
No. of part line	2-part	1-part	2-part	1-part	2-part	1-part	1-part	1-part	1-part	1-part	1-part	1-part	1-part	
Working radius (m)														
16.0	25.0/16.9	13.5/17.1												
18.0	25.0	13.5	14.9/19.8		19.5/19.5	13.5/19.7								
20.0	25.0	13.5	14.8	13.5/20.3	19.3	13.5			12.9/21.8					
22.0	25.0	13.5	14.5	13.5	18.8	13.5			12.8		7.0/23.4			
24.0	24.4	13.5	14.2	13.5	18.3	13.5	10.6/24.3	12.7		6.9		4.9/24.5		
26.0	23.4	13.5	13.9	13.5	17.8	13.5	10.4	12.5	8.6/27.8	6.8			4.8	
28.0	22.5	13.5	13.6	13.5	17.4	13.5	10.2	12.3	8.5	6.7			4.7	
30.0	21.5	13.5	13.3	13.3	16.9	13.5	10.1	12.1	8.4	6.6	5.4/30.8		4.7	
32.0	20.6	13.5	13.0	13.0	16.4	13.5	9.9	11.9	8.3	6.5	5.3	4.6	3.1/33.4	
34.0	18.9	13.5	12.7	12.7	15.9	13.5	9.7	11.8	8.2	6.4	5.3	4.5	3.0	
36.0	17.3	13.5	12.4	12.4	15.4	13.5	9.5	11.6	8.0	6.3	5.2	4.5	3.0	
38.0	15.8	13.5	12.1	12.1	15.0	13.5	9.4	11.4	7.9	6.2	5.2	4.4	3.0	
40.0	14.5	13.5	11.8	11.8	14.5	13.5	9.2	11.2	7.8	6.1	5.1	4.3	3.0	
42.0	13.3	13.3	11.5	11.5	13.8	13.5	9.0	11.1	7.6	6.0	5.1	4.3	3.0	
44.0	12.2	12.2	11.2	11.2	12.7	12.7	8.9	10.9	7.5	5.9	5.0	4.2	3.0	
46.0	11.3	11.3	10.9	10.9	11.7	11.7	8.7	10.7	7.4	5.8	5.0	4.2	2.9	
48.0	10.4	10.4	10.6	10.6	10.9	10.9	8.5	10.5	7.3	5.7	4.9	4.1	2.9	
50.0	9.6	9.6	9.9	9.9	10.0	10.0	8.3	10.3	7.1	5.6	4.9	4.0	2.9	
52.0	8.9	8.9	9.1	9.1	9.3	9.3	8.2	9.9	7.0	5.5	4.8	4.0	2.9	
54.0	8.2	8.2	8.4	8.4	8.6	8.6	8.0	9.2	6.9	5.4	4.8	3.9	2.9	
56.0	7.5	7.5	7.7	7.7	8.0	8.0	7.8	8.6	6.7	5.3	4.7	3.8	2.9	
58.0	6.9	6.9	7.1	7.1	7.4	7.4	7.6	8.0	6.6	5.2	4.7	3.8	2.8	
60.0	6.2	6.2	6.4	6.4	6.8	6.8	7.4	7.4	6.5	5.1	4.6	3.7	2.8	
62.0	5.7	5.7	5.8	5.8	6.2	6.2	6.8	6.9	6.4	5.0	4.5	3.6	2.8	
64.0	5.1	5.1	5.2	5.2	5.6	5.6	6.2	6.3	6.2	4.9	4.5	3.6	2.8	
66.0	4.8/65.6	4.8	4.7/66.1	4.7	5.1	5.1	5.6	5.8	6.1	4.8	4.4	3.5	2.8	
68.0		4.8/66.4		4.7/66.9	4.6	4.6	5.1	5.3	5.6	4.7	4.4	3.4	2.8	
70.0					4.1	4.1	4.6	4.8	5.1	4.6	4.3	3.4	2.7	
72.0					3.9/71.5	3.9	4.1	4.3	4.6	4.5	4.3	3.3	2.7	
74.0						3.9/72.3	3.8/73.0	3.9	4.2	4.2	4.2	3.2	2.7	
76.0								3.5	3.7	3.8	4.2	3.2	2.7	
78.0								3.1	3.3	3.4	3.8	3.1	2.7	
80.0									3.1/79.1	3.1	3.4	3.0	2.6	
82.0										2.7	3.0	2.9	2.6	
84.0										2.5/83.6	2.6	2.6	2.6	
86.0											2.4/85.2		2.6	
88.0													2.3	

(EC401057)

■ w/64.00m Boom

Fly jib length (m)	12.20				18.30				24.40			30.50		36.55	
	10		30		10		30	10	30	10	30	10	30		
	No. of part line	2-part	1-part	2-part	1-part	2-part	1-part	1-part	1-part	1-part	1-part	1-part	1-part	1-part	
16.0	25.0/17.4	13.5/17.7													
18.0	25.0	13.5													
20.0	24.6	13.5	14.9/20.4	13.5/20.8	19.4	13.5/20.3									
22.0	23.8	13.5	14.6	13.5	18.8	13.5		12.9/22.4							
24.0	22.9	13.5	14.2	13.5	18.2	13.5	10.6/24.8	12.7		7.0			4.9/25.0		
26.0	22.0	13.5	13.9	13.5	17.6	13.5	10.5	12.5		6.9			4.8		
28.0	21.2	13.5	13.6	13.5	17.0	13.5	10.3	12.4	8.6/28.3	6.8			4.8		
30.0	20.3	13.5	13.3	13.3	16.4	13.5	10.1	12.2	8.4	6.7	5.4/31.4		4.7		
32.0	19.5	13.5	12.9	12.9	15.8	13.5	10.0	12.0	8.3	6.6	5.3		4.6		
34.0	18.6	13.5	12.6	12.6	15.2	13.5	9.8	11.9	8.2	6.5	5.3		4.6	3.1	
36.0	17.1	13.5	12.3	12.3	14.5	13.5	9.6	11.7	8.1	6.4	5.2		4.5	3.0	
38.0	15.6	13.5	11.9	11.9	13.9	13.5	9.5	11.5	8.0	6.3	5.2		4.4	3.0	
40.0	14.3	13.5	11.6	11.6	13.3	13.3	9.3	11.3	7.8	6.2	5.1		4.4	3.0	
42.0	13.1	13.1	11.3	11.3	12.7	12.7	9.1	11.2	7.7	6.1	5.1		4.3	3.0	
44.0	12.0	12.0	11.0	11.0	12.1	12.1	9.0	11.0	7.6	6.0	5.0		4.3	3.0	
46.0	11.1	11.1	10.6	10.6	11.5	11.5	8.8	10.8	7.5	5.9	5.0		4.2	2.9	
48.0	10.2	10.2	10.3	10.3	10.7	10.7	8.6	10.7	7.3	5.8	4.9		4.1	2.9	
50.0	9.4	9.4	9.7	9.7	9.8	9.8	8.5	10.5	7.2	5.7	4.9		4.1	2.9	
52.0	8.7	8.7	8.9	8.9	9.1	9.1	8.3	9.7	7.1	5.6	4.8		4.0	2.9	
54.0	8.0	8.0	8.2	8.2	8.4	8.4	8.1	9.0	7.0	5.5	4.8		3.9	2.9	
56.0	7.3	7.3	7.5	7.5	7.8	7.8	8.0	8.4	6.8	5.4	4.7		3.9	2.9	
58.0	6.6	6.6	6.8	6.8	7.1	7.1	7.8	7.8	6.7	5.3	4.7		3.8	2.8	
60.0	6.0	6.0	6.2	6.2	6.5	6.5	7.2	7.2	6.6	5.2	4.6		3.7	2.8	
62.0	5.4	5.4	5.5	5.5	5.9	5.9	6.5	6.6	6.5	5.1	4.6		3.7	2.8	
64.0	4.8	4.8	5.0	5.0	5.3	5.3	5.9	6.0	6.3	5.0	4.5		3.6	2.8	
66.0	4.3	4.3	4.4	4.4	4.8	4.8	5.4	5.5	6.0	4.9	4.5		3.6	2.8	
68.0	3.8	3.8	3.9	3.9	4.3	4.3	4.8	5.0	5.4	4.8	4.4		3.5	2.8	
70.0	3.8/68.3	3.8/69.0	3.8/68.8	3.8/69.6	3.9	3.9	4.3	4.5	4.9	4.7	4.4		3.4	2.7	
72.0					3.4	3.4	3.9	4.1	4.4	4.3	4.3		3.4	2.7	
74.0					3.1	3.1	3.4	3.7	4.0	3.9	4.3		3.3	2.7	
76.0					3.1/74.2	3.1/74.9	3.0/75.7	3.3	3.5	3.5	4.0		3.2	2.7	
78.0								2.9	3.1	3.2	3.6		3.2	2.7	
80.0								2.5	2.7	2.8	3.2		3.0	2.7	
82.0										2.5	2.8		2.6	2.6	
84.0											2.4		2.6	2.6	
86.0													2.4	2.4	

(EC401057)

■ w/67.05m Boom

Fly jib length (m)	12.20				18.30				24.40			30.50		36.55	
	10		30		10		30	10	30	10	30	10	30		
	No. of part line	2-part	1-part	2-part	1-part	2-part	1-part	1-part	1-part	1-part	1-part	1-part	1-part	1-part	
16.0	25.0/17.9														
18.0	24.9	13.5/18.2													
20.0	24.0	13.5	14.9/20.9	13.5/21.4	19.5/20.5	13.5/20.8									
22.0	23.2	13.5	14.6	13.5	19.0	13.5		12.9/22.9							
24.0	22.4	13.5	14.2	13.5	18.3	13.5	10.6/25.3	12.8		7.0/24.5			4.9/25.6		
26.0	21.5	13.5	13.8	13.5	17.7	13.5	10.5	12.6		6.9			4.8		
28.0	20.7	13.5	13.4	13.4	17.1	13.5	10.3	12.4	8.6/28.8	6.8			4.8		
30.0	19.9	13.5	13.0	13.0	16.5	13.5	10.2	12.3	8.5	6.7	5.4/31.9		4.7		
32.0	19.0	13.5	12.6	12.6	15.9	13.5	10.0	12.1	8.4	6.6	5.3		4.7		
34.0	18.2	13.5	12.2	12.2	15.3	13.5	9.9	11.9	8.2	6.5	5.3		4.6	3.1/34.5	
36.0	16.8	13.5	11.9	11.9	14.7	13.5	9.7	11.8	8.1	6.4	5.3		4.5	3.0	
38.0	15.4	13.5	11.5	11.5	14.1	13.5	9.5	11.6	8.0	6.3	5.2		4.5	3.0	
40.0	14.1	13.5	11.1	11.1	13.5	13.5	9.4	11.4	7.9	6.2	5.2		4.4	3.0	
42.0	12.9	12.9	10.7	10.7	12.8	12.8	9.2	11.3	7.8	6.1	5.1		4.3	3.0	
44.0	11.8	11.8	10.3	10.3	12.2	12.2	9.1	11.1	7.6	6.0	5.1		4.3	3.0	
46.0	10.9	10.9	9.9	9.9	11.3	11.3	8.9	10.9	7.5	5.9	5.0		4.2	3.0	
48.0	10.0	10.0	9.5	9.5	10.4	10.4	8.8	10.8	7.4	5.9	5.0		4.2	2.9	
50.0	9.2	9.2	9.1	9.1	9.6	9.6	8.6	10.3	7.3	5.8	4.9		4.1	2.9	
52.0	8.4	8.4	8.7	8.7	8.9	8.9	8.4	9.5	7.2	5.7	4.9		4.0	2.9	
54.0	7.7	7.7	8.0	8.0	8.2	8.2	8.3	8.8	7.1	5.6	4.8		4.0	2.9	
56.0	7.0	7.0	7.3	7.3	7.5	7.5	8.1	8.2	6.9	5.5	4.8		3.9	2.9	
58.0	6.3	6.3	6.5	6.5	6.8	6.8	7.6	7.6	6.8	5.4	4.7		3.9	2.9	
60.0	5.7	5.7	5.9	5.9	6.2	6.2	6.9	6.9	6.7	5.3	4.7		3.8	2.8	
62.0	5.1	5.1	5.3	5.3	5.6	5.6	6.3	6.3	6.6	5.2	4.6		3.7	2.8	
64.0	4.5	4.5	4.7	4.7	5.0	5.0	5.7	5.7	6.3	5.1	4.6		3.7	2.8	
66.0	4.0	4.0	4.2	4.2	4.5	4.5	5.1	5.2	5.7	5.0	4.5		3.6	2.8	
68.0	3.6	3.6	3.7	3.7	4.0	4.0	4.6	4.7	5.2	4.9	4.5		3.6	2.8	
70.0	3.1	3.1	3.2	3.2	3.6	3.6	4.1	4.2	4.7	4.5	4.4		3.5	2.8	
72.0	2.9/70.9	2.9/71.7	2.9/71.2		2.9	3.1	3.6	3.8	4.2	4.1	4.4		3.4	2.7	
74.0				2.9/72.4			3.0/72.7	3.2	3.4	3.7	4.2		3.4	2.7	
76.0							2.7	3.0	3.3	3.3	3.7		3.3	2.7	
78.0								2.6	2.9	2.9	3.3		3.1	2.7	
80.0									2.5	2.5	2.9		2.7	2.7	
82.0											2.5		2.7	2.7	
84.0													2.5	2.5	

(EC401057)

■ w/70.10m Boom

Fly jib length (m)	12.20				18.30				24.40		30.50		36.55	
Fly jib offset angle (°)	10		30		10		30	10	30	10	30	10	30	
No. of part line	2-part	1-part	2-part	1-part	2-part	1-part	1-part	1-part	1-part	1-part	1-part	1-part	1-part	
Working radius (m)														
18.0	22.6/18.5	13.5/18.7												
20.0	21.9	13.5												
22.0	21.2	13.5	14.9/21.4	13.5/21.9	18.0/21.1	13.5/21.3			12.9/23.4					
24.0	20.4	13.5	14.2	13.5	17.1	13.5		10.6/25.8	12.8		7.0/25.0			
26.0	19.7	13.5	13.7	13.5	16.5	13.5		10.5	12.6		6.9		4.9/26.1	
28.0	18.9	13.5	13.2	13.2	15.9	13.5		10.4	12.5	8.6/29.4	6.8		4.8	
30.0	18.2	13.5	12.7	12.7	15.4	13.5		10.2	12.3	8.5	6.7		4.7	
32.0	17.4	13.5	12.2	12.2	14.8	13.5		10.1	12.2	8.4	6.6	5.4/32.4	4.7	
34.0	16.7	13.5	11.7	11.7	14.2	13.5		9.9	12.0	8.3	6.5	5.3	4.6	
36.0	15.9	13.5	11.2	11.2	13.7	13.5		9.8	11.8	8.2	6.5	5.3	4.6	
38.0	15.1	13.5	10.7	10.7	13.1	13.1		9.6	11.7	8.1	6.4	5.2	4.5	
40.0	13.8	13.5	10.2	10.2	12.5	12.5		9.5	11.5	7.9	6.3	5.2	4.4	
42.0	12.6	12.6	9.7	9.7	11.9	11.9		9.3	11.4	7.8	6.2	5.1	4.4	
44.0	11.5	11.5	9.3	9.3	11.4	11.4		9.2	11.2	7.7	6.1	5.1	4.3	
46.0	10.5	10.5	8.8	8.8	10.8	10.8		9.0	11.0	7.6	6.0	5.0	4.3	
48.0	9.7	9.7	8.3	8.3	10.1	10.1		8.9	10.8	7.5	5.9	5.0	4.2	
50.0	8.9	8.9	7.8	7.8	9.3	9.3		8.7	10.0	7.4	5.8	4.9	4.1	
52.0	8.1	8.1	7.3	7.3	8.6	8.6		8.6	9.2	7.3	5.7	4.9	4.1	
54.0	7.3	7.3	6.8	6.8	7.8	7.8		8.4	8.5	7.1	5.6	4.9	4.0	
56.0	6.5	6.5	6.3	6.3	7.1	7.1		8.0	7.9	7.0	5.6	4.8	4.0	
58.0	5.9	5.9	5.8	5.8	6.4	6.4		7.3	7.2	6.9	5.5	4.8	3.9	
60.0	5.2	5.2	5.3	5.3	5.8	5.8		6.6	6.5	6.8	5.4	4.7	3.8	
62.0	4.7	4.7	4.8	4.8	5.2	5.2		6.0	5.9	6.6	5.3	4.7	3.8	
64.0	4.1	4.1	4.3	4.3	4.6	4.6		5.3	5.4	6.0	5.2	4.6	3.7	
66.0	3.6	3.6	3.8	3.8	4.1	4.1		4.8	4.8	5.4	5.1	4.6	3.7	
68.0	3.1	3.1	3.3	3.3	3.6	3.6		4.2	4.3	4.8	4.6	4.5	3.6	
70.0		2.9/68.7		3.1/68.8	3.2	3.2		3.7	3.8	4.3	4.1	4.5	3.5	
72.0						3.0/70.7		3.3	3.4	3.8	3.7	4.3	3.5	
74.0								2.8	3.0	3.4	3.3	3.8	3.4	
76.0										2.9	2.9	3.4	3.0	
78.0												3.0	2.7	
80.0												2.6	2.7	
82.0													2.6	

(EC401057)

■ w/73.15m Boom

Fly jib length (m)	12.20				18.30				24.40		30.50		36.55	
Fly jib offset angle (°)	10		30		10		30	10	30	10	30	10	30	
No. of part line	2-part	1-part	2-part	1-part	2-part	1-part	1-part	1-part	1-part	1-part	1-part	1-part	1-part	
Working radius (m)														
18.0	19.6/19.0	13.5/19.3												
20.0	19.2	13.5												
22.0	18.5	13.5	14.8	13.5/22.4	17.5	13.5								
24.0	17.9	13.5	14.3	13.5	16.9	13.5			12.9		7.0/25.5			
26.0	17.2	13.5	13.8	13.5	16.4	13.5		10.6/26.4	12.5		6.9		4.9/26.6	
28.0	16.6	13.5	13.3	13.3	15.8	13.5		10.4	12.1	8.6/29.9	6.8		4.8	
30.0	15.9	13.5	12.8	12.8	15.2	13.5		10.3	11.7	8.5	6.8		4.8	
32.0	15.3	13.5	12.3	12.3	14.7	13.5		10.1	11.3	8.4	6.7	5.4/32.9	4.7	
34.0	14.7	13.5	11.8	11.8	14.1	13.5		10.0	10.9	8.3	6.6	5.3	4.6	
36.0	14.0	13.5	11.3	11.3	13.5	13.5		9.8	10.5	8.2	6.5	5.3	4.6	
38.0	13.4	13.4	10.8	10.8	13.0	13.0		9.7	10.1	8.1	6.4	5.2	4.5	
40.0	12.7	12.7	10.3	10.3	12.4	12.4		9.6	9.7	8.0	6.3	5.2	4.5	
42.0	12.1	12.1	9.8	9.8	11.9	11.9		9.4	9.3	7.9	6.2	5.1	4.4	
44.0	11.3	11.3	9.3	9.3	11.3	11.3		9.3	8.9	7.8	6.1	5.1	4.4	
46.0	10.3	10.3	8.8	8.8	10.7	10.7		9.1	8.6	7.7	6.1	5.1	4.3	
48.0	9.5	9.5	8.3	8.3	9.9	9.9		9.0	8.2	7.6	6.0	5.0	4.2	
50.0	8.6	8.6	7.8	7.8	9.1	9.1		8.8	7.8	7.4	5.9	5.0	4.2	
52.0	7.8	7.8	7.3	7.3	8.4	8.4		8.7	7.4	7.3	5.8	4.9	4.1	
54.0	7.0	7.0	6.8	6.8	7.6	7.6		8.5	7.0	7.2	5.7	4.9	4.1	
56.0	6.3	6.3	6.3	6.3	6.8	6.8		7.8	6.6	7.1	5.6	4.8	4.0	
58.0	5.6	5.6	5.8	5.8	6.1	6.1		7.0	6.2	7.0	5.5	4.8	3.9	
60.0	5.0	5.0	5.2	5.2	5.5	5.5		6.4	5.8	6.9	5.4	4.7	3.9	
62.0	4.4	4.4	4.6	4.6	4.9	4.9		5.7	5.4	6.3	5.4	4.7	3.8	
64.0	3.8	3.8	4.1	4.1	4.3	4.3		5.1	5.0	5.7	5.3	4.7	3.8	
66.0	3.3	3.3	3.5	3.5	3.8	3.8		4.5	4.6	5.1	4.8	4.6	3.7	
68.0		3.1/66.6	3.0	3.0	3.3	3.3		4.0	4.0	4.6	4.3	4.6	3.7	
70.0				2.9/68.8	2.9	2.9		3.5	3.6	4.1	3.9	4.5	3.6	
72.0						2.8/70.7		3.0	3.1	3.6	3.4	4.1	3.5	
74.0										3.1	3.0	3.6	3.2	
76.0										2.7		3.2	2.8	
78.0												2.8	2.7	
80.0													2.7	

(EC401057)

Notes — Fly jib capacities

1. Capacities included in this chart are the maximum allowable, and are based on machine standing level on firm supporting surface under ideal job conditions.
2. Capacities are in metric tons, and are based on 78% of minimum tipping loads except the figures surrounded by bold lines which are based on other factor of machine structural limitation.
3. Capacities are based on freely suspended loads and make no allowance for such factors as the effect of wind, sudden stopping of loads, supporting surface conditions, and operating speeds. Operator must reduce load ratings to take such conditions into account. Deduction from rated jib capacities must be made for weight of hook block, weighted ball/hook, sling, load weighing devices, or other suspended gear.
Hook block weight is as follows;
35/25t0.9t 13.5t0.6t
4. All capacities are rated for 360° swing.
5. Least stable rated position is over the side.
6. An 86.3ton counterweight 1.7ton auxiliary weight and 14.0ton carbody weight are required for all capacities on these chart.
7. Maximum fly jib length permitted is 36.55m, and maximum boom and fly jib combination length permitted is 73.15m boom plus 36.55m fly jib.

Liftcrane Capacities with fly jib on top of the main boom

■ w/45.70m Boom

Fly jib length (m)	12.20		18.30		24.40		30.50		36.55	
Fly jib offset angle (i)	10	30	10	30	10	30	10	30	10	30
Working radius (m)										
9.9	80.0	80.0	78.9	79.1	78.0	77.5	76.5	75.9	74.9	74.1
10.0	80.0	79.8	78.7	78.9	77.8	77.3	76.3	75.6	74.7	73.8
12.0	75.4	75.2	74.0	74.2	73.2	72.7	71.7	71.4	70.6	70.0
14.0	65.1	64.7	64.2	64.2	64.0	63.1	63.2	62.0	62.4	60.8
16.0	53.4	53.0	52.5	52.7	52.4	51.7	51.6	50.6	50.8	49.5
18.0	44.9	44.6	44.0	44.2	43.9	43.3	43.1	42.3	42.3	41.3
20.0	38.4	38.1	37.6	37.8	37.4	36.9	36.7	36.0	35.9	35.0
22.0	33.2	33.0	32.5	32.8	32.3	31.9	31.6	31.0	30.8	30.1
24.0	29.1	28.9	28.4	28.7	28.2	27.9	27.5	27.0	26.8	26.1
26.0	25.7	25.6	25.0	25.3	24.9	24.6	24.1	23.7	23.4	22.9
28.0	22.9	22.8	22.2	22.5	22.0	21.8	21.3	21.0	20.6	20.1
30.0	20.5	20.4	19.8	20.1	19.6	19.4	18.9	18.6	18.2	17.8
32.0	18.4	18.3	17.7	18.1	17.6	17.4	16.9	16.6	16.2	15.8
34.0	16.6	16.5	15.9	16.3	15.8	15.6	15.1	14.9	14.4	14.1
36.0	15.0	15.0	14.4	14.8	14.2	14.1	13.6	13.4	12.9	12.6
38.0	13.7	13.6	13.0	13.4	12.9	12.8	12.2	12.1	11.5	11.3
40.0	12.5	12.4	11.8	12.2	11.7	11.6	11.0	10.9	10.3	10.2
41.2	11.8	11.8	11.2	11.6	11.0	10.9	10.3	10.3	9.7	9.6

(EC403027)

■ w/48.75m Boom

Fly jib length (m)	12.20		18.30		24.40		30.50		36.55	
Fly jib offset angle (i)	10	30	10	30	10	30	10	30	10	30
Working radius (m)										
10.5	73.3	73.1	71.9	72.1	71.0	70.5	69.5	68.5	67.9	67.1
12.0	70.3	70.0	68.9	69.1	68.0	67.5	66.5	65.9	64.9	64.1
14.0	66.0	65.6	65.0	65.2	64.2	63.8	62.7	61.4	60.6	60.0
16.0	53.3	53.0	52.5	52.6	52.3	51.6	51.5	50.6	50.8	49.5
18.0	44.8	44.5	44.0	44.2	43.8	43.2	43.1	42.3	42.3	41.3
20.0	38.3	38.0	37.5	37.7	37.4	36.9	36.6	35.9	35.9	35.0
22.0	33.2	32.9	32.4	32.7	32.3	31.8	31.5	31.0	30.8	30.1
24.0	29.0	28.8	28.3	28.6	28.2	27.8	27.4	27.0	26.7	26.1
26.0	25.6	25.4	24.9	25.2	24.8	24.5	24.1	23.6	23.4	22.8
28.0	22.8	22.6	22.1	22.4	21.9	21.7	21.3	20.9	20.5	20.1
30.0	20.3	20.2	19.7	20.0	19.5	19.3	18.9	18.5	18.2	17.7
32.0	18.3	18.2	17.6	18.0	17.5	17.3	16.8	16.5	16.1	15.7
34.0	16.5	16.4	15.8	16.2	15.7	15.5	15.0	14.8	14.3	14.0
36.0	14.9	14.8	14.2	14.6	14.1	14.0	13.4	13.3	12.8	12.5
38.0	13.5	13.4	12.9	13.2	12.7	12.6	12.1	11.9	11.4	11.2
40.0	12.3	12.2	11.6	12.0	11.5	11.4	10.9	10.7	10.2	10.0
42.0	11.2	11.1	10.6	11.0	10.4	10.3	9.8	9.7	9.1	9.0
43.9	10.3	10.2	9.7	10.0	9.5	9.4	8.9	8.8	8.2	8.0

(EC403027)

■ w/51.80m Boom

Fly jib length (m)	12.20		18.30		24.40		30.50		36.55	
Fly jib offset angle (j)	10	30	10	30	10	30	10	30	10	30
Working radius (m)										
11.0	65.0	65.0	65.0	65.0	64.2	63.7	62.7	62.0	61.2	60.3
12.0	64.7	64.4	63.3	63.5	62.4	61.9	61.0	60.3	59.4	58.5
14.0	61.1	60.8	59.8	60.0	59.0	58.5	57.5	55.4	56.0	54.0
16.0	53.0	52.7	52.2	52.3	52.1	51.4	51.3	50.3	50.6	49.3
18.0	44.5	44.2	43.7	43.9	43.6	43.0	42.8	42.0	42.1	41.0
20.0	38.0	37.7	37.2	37.4	37.1	36.6	36.4	35.7	35.6	34.7
22.0	32.8	32.6	32.1	32.4	32.0	31.5	31.3	30.7	30.6	29.8
24.0	28.7	28.5	28.0	28.3	27.9	27.5	27.2	26.6	26.5	25.8
26.0	25.3	25.1	24.6	24.9	24.5	24.1	23.8	23.3	23.1	22.5
28.0	22.4	22.3	21.7	22.1	21.6	21.3	21.0	20.6	20.3	19.7
30.0	20.0	19.9	19.3	19.7	19.2	19.0	18.6	18.2	17.9	17.4
32.0	17.9	17.8	17.3	17.6	17.1	16.9	16.5	16.2	15.8	15.4
34.0	16.1	16.0	15.5	15.8	15.3	15.2	14.7	14.4	14.0	13.7
36.0	14.5	14.4	13.9	14.3	13.8	13.6	13.1	12.9	12.5	12.2
38.0	13.1	13.1	12.5	12.9	12.4	12.2	11.7	11.6	11.1	10.8
40.0	11.9	11.8	11.3	11.7	11.1	11.0	10.5	10.4	9.9	9.7
42.0	10.8	10.7	10.2	10.6	10.1	10.0	9.4	9.3	8.8	8.6
44.0	9.8	9.8	9.2	9.6	9.1	9.0	8.5	8.4	7.7	7.5
46.0	8.9	8.9	8.3	8.7	8.2	8.1	7.5	7.4	6.6	6.5
46.5	8.7	8.7	8.1	8.5	8.0	7.9	7.2	7.2	6.4	6.3

(EC403027)

■ w/54.85m Boom

Fly jib length (m)	12.20		18.30		24.40		30.50		36.55	
Fly jib offset angle (j)	10	30	10	30	10	30	10	30	10	30
Working radius (m)										
11.5	61.0	60.7	59.6	59.8	58.8	58.2	57.3	56.5	55.7	54.8
12.0	60.2	59.9	58.8	59.0	58.0	57.4	56.5	55.8	54.9	54.0
14.0	56.9	56.6	55.5	55.7	54.7	54.2	53.3	52.6	51.8	50.9
16.0	53.6	53.4	52.3	52.5	51.6	51.1	50.2	49.6	48.8	47.0
18.0	44.4	44.1	43.6	43.8	43.5	42.9	42.8	42.0	42.1	41.0
20.0	37.9	37.6	37.1	37.4	37.0	36.5	36.3	35.6	35.6	34.7
22.0	32.8	32.5	32.0	32.3	31.9	31.5	31.2	30.6	30.6	29.7
24.0	28.6	28.4	27.9	28.2	27.8	27.4	27.1	26.6	26.4	25.7
26.0	25.2	25.0	24.5	24.8	24.4	24.1	23.7	23.3	23.1	22.4
28.0	22.3	22.2	21.7	22.0	21.6	21.3	20.9	20.5	20.2	19.7
30.0	19.9	19.8	19.2	19.6	19.1	18.9	18.5	18.1	17.8	17.4
32.0	17.8	17.7	17.2	17.5	17.1	16.8	16.4	16.1	15.8	15.3
34.0	16.0	15.9	15.4	15.7	15.3	15.1	14.6	14.3	14.0	13.6
36.0	14.4	14.3	13.8	14.2	13.7	13.5	13.0	12.8	12.4	12.1
38.0	13.0	12.9	12.4	12.8	12.3	12.1	11.7	11.4	11.0	10.7
40.0	11.8	11.7	11.1	11.5	11.0	10.9	10.4	10.2	9.8	9.5
42.0	10.6	10.6	10.0	10.4	9.9	9.8	9.3	9.2	8.7	8.4
44.0	9.6	9.6	9.1	9.4	8.9	8.8	8.3	8.2	7.5	7.3
46.0	8.8	8.7	8.2	8.6	8.0	8.0	7.3	7.2	6.5	6.3
48.0	7.9	7.9	7.3	7.8	7.1	7.0	6.3	6.3	5.5	5.4
49.1	7.5	7.5	6.9	7.3	6.6	6.6	5.9	5.8	5.1	5.0

(EC403027)

■ w/57.90m Boom

Fly jib length (m)	12.20		18.30		24.40		30.50		36.55	
Fly jib offset angle (°)	10	30	10	30	10	30	10	30	10	30
Working radius (m)										
12.0	55.9	55.6	54.5	54.7	57.3	53.2	52.2	51.5	50.7	49.7
14.0	52.9	52.6	51.5	51.7	50.7	50.2	49.3	48.6	47.8	46.9
16.0	49.8	49.6	48.5	48.8	47.8	47.3	46.4	45.8	45.0	44.1
18.0	44.2	43.9	43.4	43.6	43.2	42.7	42.2	41.8	41.1	40.5
20.0	37.7	37.4	36.9	37.2	36.9	36.3	36.2	35.4	35.5	34.5
22.0	32.5	32.3	31.8	32.1	31.7	31.3	31.1	30.4	30.4	29.6
24.0	28.4	28.2	27.7	28.0	27.6	27.2	27.0	26.4	26.3	25.6
26.0	25.0	24.8	24.3	24.6	24.2	23.9	23.6	23.1	22.9	22.3
28.0	22.1	21.9	21.4	21.8	21.4	21.1	20.7	20.3	20.1	19.5
30.0	19.7	19.5	19.0	19.4	18.9	18.7	18.3	17.9	17.7	17.2
32.0	17.6	17.5	16.9	17.3	16.9	16.6	16.2	15.9	15.6	15.1
34.0	15.8	15.6	15.1	15.5	15.1	14.8	14.4	14.1	13.8	13.4
36.0	14.2	14.1	13.5	13.9	13.5	13.3	12.8	12.6	12.2	11.9
38.0	12.8	12.7	12.1	12.5	12.1	11.9	11.5	11.2	10.8	10.5
40.0	11.5	11.4	10.9	11.3	10.8	10.7	10.2	10.0	9.6	9.3
42.0	10.4	10.3	9.8	10.2	9.7	9.6	9.1	8.9	8.4	8.1
44.0	9.4	9.3	8.8	9.2	8.7	8.6	8.1	7.9	7.2	7.0
46.0	8.5	8.5	7.9	8.3	7.8	7.7	7.0	6.8	6.2	6.0
48.0	7.7	7.6	7.0	7.5	6.8	6.7	6.1	5.9	5.3	5.1
50.0	6.9	6.8	6.1	6.6	5.9	5.9	5.2	5.1	4.4	4.3
51.8	6.2	6.1	5.5	5.9	5.2	5.2	4.5	4.4		

(EC403027)

■ w/60.95m Boom

Fly jib length (m)	12.20		18.30		24.40		30.50		36.55	
Fly jib offset angle (°)	10	30	10	30	10	30	10	30	10	30
Working radius (m)										
12.6	49.0	49.0	48.9	49.0	48.1	47.5	46.7	45.9	45.2	44.2
14.0	48.3	47.9	46.9	47.1	46.2	45.6	44.8	44.0	43.3	42.4
16.0	45.5	45.2	44.2	44.4	43.2	42.9	42.1	41.4	40.7	39.8
18.0	41.1	40.9	40.2	40.1	39.1	38.7	38.1	37.8	37.0	36.4
20.0	37.4	37.1	36.6	36.9	36.6	36.0	35.9	35.2	35.2	34.3
22.0	32.2	32.0	31.5	31.8	31.4	31.0	30.8	30.1	30.1	29.3
24.0	28.1	27.8	27.4	27.7	27.3	26.9	26.7	26.1	26.0	25.3
26.0	24.6	24.4	24.0	24.3	23.9	23.5	23.3	22.8	22.6	22.0
28.0	21.8	21.6	21.1	21.4	21.1	20.7	20.4	20.0	19.8	19.2
30.0	19.3	19.2	18.7	19.0	18.6	18.3	18.0	17.6	17.4	16.8
32.0	17.2	17.1	16.6	17.0	16.5	16.3	15.9	15.6	15.3	14.8
34.0	15.4	15.3	14.8	15.2	14.7	14.5	14.1	13.8	13.5	13.1
36.0	13.8	13.7	13.2	13.6	13.1	12.9	12.5	12.3	11.9	11.5
38.0	12.4	12.3	11.8	12.2	11.7	11.6	11.1	10.9	10.5	10.2
40.0	11.2	11.1	10.6	10.9	10.5	10.3	9.9	9.7	9.3	8.9
42.0	10.0	10.0	9.4	9.8	9.4	9.2	8.8	8.5	8.0	7.7
44.0	9.0	9.0	8.4	8.8	8.4	8.2	7.6	7.4	6.8	6.5
46.0	8.1	8.1	7.5	7.9	7.3	7.2	6.5	6.4	5.8	5.5
48.0	7.2	7.2	6.5	7.0	6.3	6.2	5.6	5.4	4.8	4.6
50.0	6.4	6.3	5.6	6.1	5.5	5.4	4.7	4.6	4.0	
52.0	5.6	5.5	4.9	5.3	4.7	4.6	3.9			
54.0	4.8	4.8	4.2	4.6	4.0	3.9				
54.4	4.7	4.7	4.0	4.5	3.8	3.8				

(EC403027)

■ w/64.00m Boom

Fly jib length (m)	12.20		18.30		24.40		30.50		36.55	
Fly jib offset angle (°)	10	30	10	30	10	30	10	30	10	30
Working radius (m)										
13.1	46.0	45.6	44.6	44.8	43.8	43.2	42.4	41.6	41.0	39.9
14.0	44.8	44.4	43.4	43.6	42.7	41.2	41.3	40.5	39.9	38.9
16.0	42.2	41.9	40.9	41.1	40.2	39.6	38.8	38.1	37.4	36.5
18.0	37.1	36.9	38.4	28.6	37.7	37.2	36.4	35.8	35.1	34.2
20.0	35.6	35.4	34.7	34.6	33.6	33.2	32.6	32.3	31.5	30.9
22.0	32.0	31.8	31.3	31.6	31.3	30.8	30.6	30.0	30.0	29.1
24.0	27.9	27.6	27.2	27.5	27.1	26.7	26.5	25.9	25.8	25.1
26.0	24.4	24.2	23.8	24.1	23.7	23.3	23.1	22.6	22.4	21.8
28.0	21.6	21.4	20.9	21.2	20.9	20.5	20.2	19.8	19.6	19.0
30.0	19.1	19.0	18.5	18.8	18.4	18.1	17.8	17.4	17.2	16.7
32.0	17.0	16.9	16.4	16.7	16.3	16.1	15.7	15.4	15.1	14.6
34.0	15.2	15.1	14.6	14.9	14.5	14.3	13.9	13.6	13.3	12.9
36.0	13.6	13.5	13.0	13.4	12.9	12.7	12.3	12.0	11.7	11.3
38.0	12.2	12.1	11.6	12.0	11.5	11.3	10.9	10.7	10.3	10.0
40.0	10.9	10.8	10.3	10.7	10.3	10.1	9.7	9.5	9.0	8.6
42.0	9.8	9.7	9.2	9.6	9.2	9.0	8.5	8.3	7.7	7.4
44.0	8.8	8.7	8.2	8.6	8.1	7.9	7.3	7.1	6.6	6.3
46.0	7.9	7.8	7.2	7.6	7.0	6.9	6.3	6.1	5.5	5.2
48.0	6.9	6.9	6.2	6.7	6.1	5.9	5.3	5.1	4.5	4.3
50.0	6.0	6.0	5.3	5.8	5.2	5.1	4.4	4.3		
52.0	5.2	5.2	4.5	5.0	4.4	4.3				
54.0	4.5	4.5	3.8	4.3						
56.0	3.8	3.8		3.6						

(EC403027)

■ w/67.05m Boom

Fly jib length (m)	12.20		18.30		24.40		30.50		36.55	
Fly jib offset angle (°)	10	30	10	30	10	30	10	30	10	30
Working radius (m)										
13.6	41.9	41.6	40.6	40.7	39.9	39.2	38.5	37.6	37.1	36.0
14.0	41.5	41.1	40.1	40.3	39.4	38.8	38.0	37.2	36.6	35.5
16.0	39.0	38.7	37.7	37.9	37.0	36.5	35.7	34.9	34.3	33.3
18.0	36.7	36.4	35.4	35.6	34.8	34.2	33.5	32.8	32.1	31.2
20.0	32.6	32.4	31.7	31.6	32.6	32.1	31.3	30.7	30.0	29.2
22.0	31.1	30.9	30.2	30.1	29.1	28.7	28.1	27.8	27.0	26.4
24.0	27.8	27.6	27.1	27.4	27.1	26.7	26.5	25.9	25.5	24.9
26.0	24.4	24.2	23.7	24.0	23.7	23.3	23.1	22.5	22.4	21.7
28.0	21.5	21.3	20.8	21.2	20.8	20.5	20.2	19.7	19.6	19.0
30.0	19.0	18.9	18.4	18.8	18.4	18.1	17.8	17.4	17.2	16.6
32.0	16.9	16.8	16.3	16.7	16.3	16.0	15.7	15.3	15.1	14.6
34.0	15.1	15.0	14.5	14.9	14.5	14.2	13.9	13.5	13.3	12.8
36.0	13.5	13.4	12.9	13.3	12.9	12.6	12.3	12.0	11.7	11.3
38.0	12.1	12.0	11.5	11.9	11.5	11.3	10.9	10.6	10.3	9.9
40.0	10.8	10.7	10.2	10.6	10.2	10.0	9.6	9.4	8.9	8.5
42.0	9.7	9.6	9.1	9.5	9.1	8.9	8.4	8.1	7.6	7.3
44.0	8.7	8.6	8.1	8.5	7.9	7.8	7.2	7.0	6.4	6.1
46.0	7.7	7.6	7.0	7.5	6.9	6.7	6.1	5.9	5.4	5.1
48.0	6.7	6.7	6.0	6.5	5.9	5.8	5.2	5.0	4.4	4.2
50.0	5.9	5.8	5.1	5.6	5.0	4.9	4.3	4.1		
52.0	5.0	5.0	4.3	4.8	4.2	4.1				
54.0	4.3	4.2		4.1						
56.0	3.6	3.6								

(EC403027)

■ w/70.10m Boom

Fly jib length (m)	12.20		18.30		24.40		30.50		36.55	
Fly jib offset angle (°)	10	30	10	30	10	30	10	30	10	30
Working radius (m)										
14.2	38.0	37.6	36.6	36.8	35.9	35.3	34.6	33.7	33.2	31.3
16.0	35.9	35.6	34.6	34.8	33.9	33.3	32.6	31.8	31.3	29.5
18.0	33.7	33.4	32.5	32.7	31.8	31.3	30.5	29.8	29.2	27.5
20.0	31.6	31.3	30.4	30.6	29.8	29.3	28.5	27.8	27.2	25.7
22.0	28.6	28.4	27.7	27.6	27.8	27.4	26.6	26.0	25.3	23.9
24.0	27.1	26.9	26.2	26.1	25.1	24.7	24.1	23.8	23.0	22.4
26.0	24.0	23.8	23.4	23.7	23.4	23.0	22.6	22.2	21.5	20.9
28.0	21.2	21.0	20.5	20.8	20.5	20.1	19.9	19.4	19.3	18.7
30.0	18.7	18.5	18.1	18.4	18.1	17.7	17.5	17.0	16.9	16.3
32.0	16.6	16.4	16.0	16.3	16.0	15.7	15.4	15.0	14.8	14.3
34.0	14.8	14.6	14.1	14.5	14.1	13.9	13.5	13.2	13.0	12.5
36.0	13.2	13.0	12.5	12.9	12.5	12.3	12.0	11.6	11.4	10.9
38.0	11.7	11.6	11.1	11.5	11.1	10.9	10.5	10.3	10.0	9.5
40.0	10.5	10.4	9.9	10.3	9.9	9.7	9.3	9.0	8.5	8.1
42.0	9.3	9.2	8.8	9.2	8.7	8.5	8.0	7.7	7.2	6.8
44.0	8.3	8.2	7.6	8.1	7.5	7.3	6.8	6.5	6.0	5.7
46.0	7.2	7.1	6.5	7.0	6.4	6.2	5.7	5.5	5.0	4.6
48.0	6.3	6.2	5.5	6.0	5.4	5.3	4.7	4.5		
50.0	5.4	5.3	4.7	5.1	4.6	4.4				
52.0	4.6	4.5		4.3						
54.0	3.8									

(EC403027)

■ w/73.15m Boom

Fly jib length (m)	12.20		18.30		24.40		30.50		36.55	
Fly jib offset angle (°)	10	30	10	30	10	30	10	30	10	30
Working radius (m)										
14.7	33.0	33.0	32.5	32.6	31.8	31.2	30.5	29.6	29.2	28.0
16.0	32.4	32.0	31.1	31.1	30.5	29.9	29.2	28.4	27.9	26.8
18.0	30.4	30.0	29.1	29.1	28.5	27.9	27.2	26.5	26.0	25.0
20.0	28.4	28.1	27.2	27.4	26.6	26.1	25.4	24.8	24.1	23.4
22.0	26.6	26.4	25.7	25.6	24.8	24.3	23.6	23.3	22.5	21.9
24.0	25.1	24.9	24.2	24.1	23.1	22.7	22.1	21.8	21.0	20.4
26.0	23.6	23.4	22.7	22.6	21.6	21.2	20.6	20.3	19.5	18.9
28.0	20.9	20.7	20.3	20.6	20.1	19.7	19.1	18.8	18.0	17.4
30.0	18.5	18.3	17.9	18.2	17.9	17.5	17.3	16.8	16.5	15.9
32.0	16.4	16.2	15.8	16.1	15.8	15.5	15.2	14.8	14.6	14.1
34.0	14.5	14.4	13.9	14.3	13.9	13.7	13.4	13.0	12.8	12.3
36.0	12.9	12.8	12.3	12.7	12.3	12.1	11.8	11.4	11.2	10.7
38.0	11.5	11.4	10.9	11.3	10.9	10.7	10.3	10.0	9.7	9.2
40.0	10.2	10.1	9.7	10.1	9.7	9.5	9.0	8.7	8.3	7.8
42.0	9.1	9.0	8.5	8.9	8.4	8.2	7.7	7.4	6.9	6.5
44.0	8.0	7.9	7.3	7.8	7.2	7.0	6.5	6.2	5.8	5.4
46.0	6.9	6.8	6.2	6.7	6.1	6.0	5.4	5.2	4.7	4.4
48.0	6.0	5.9	5.2	5.7	5.1	5.0	4.5	4.2		
50.0	5.1	5.0	4.4	4.8	4.3	4.1				
52.0	4.2	4.2		4.0						

(EC403027)

Notes — Liftcrane capacities

1. These capacity charts show the figures when handling load off main boom head sheaves in a case of mounting fly jib on top of main boom.
2. Capacities included in these charts are the maximum allowable, and are based on machine standing level on firm supporting surface under ideal job conditions.
3. Capacities are in metric tons, and are not more than 78% of minimum tipping loads except the figures surrounded by bold lines which are based on other factor of machine structural limitation.
4. Capacities are based on freely suspended loads and make no allowance for such factors as the effect of wind, sudden stopping of loads, supporting surface conditions, and operating speeds. Operator must reduce load ratings to take such conditions into account. Deduction from rated capacities must be made for

weight of hook block, weighted ball/hook, sling, spreader bar, or other suspended gear.

Hook block weight is as follows:

80t1.4t 35/25t0.9t 13.5t0.6t

5. All capacities are rated for 360° swing.
6. An 86.3ton counterweight, 1.7ton auxiliary weight and 14.0ton carbody weight are required for all capacities on these chart.
7. Least stable rated condition is over the side.
8. Maximum boom and fly jib combination length permitted— 73.15m boom plus 36.55m fly jib.
9. Boom combination shall be in accordance with manufacture's standard described in "Boom Combination Diagram" of basic technical data.

Liftcrane Working Ranges

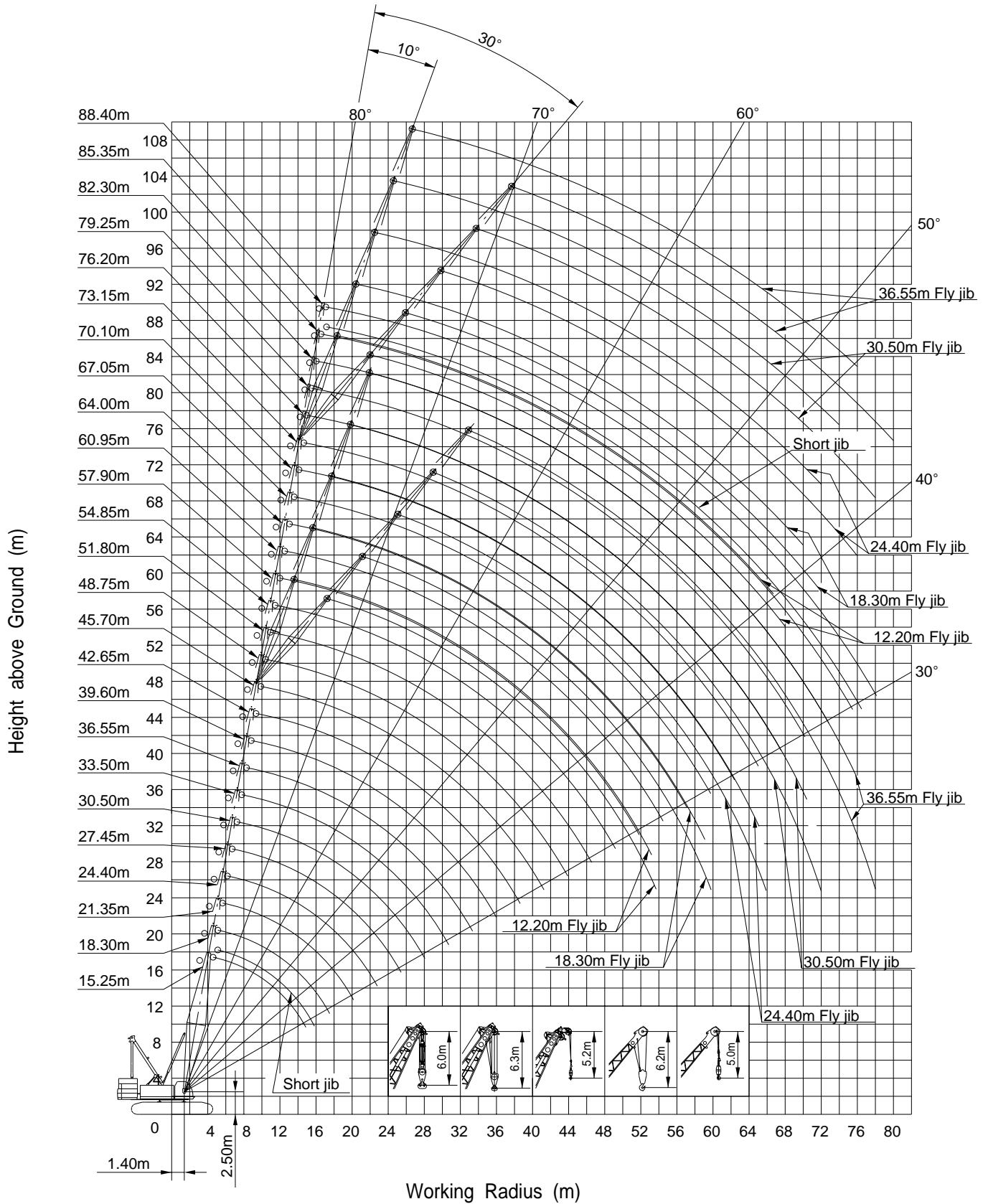

MEMO

A series of horizontal dotted lines for writing.

Hitachi Sumitomo Heavy Industries Construction Crane Co., Ltd.

12-14, Ueno 7-chome, Taito-ku, Tokyo 110-0005, Japan

Phone: 81-3-3845-1387 Facsimile: 81-3-3845-1394

- We are constantly improving our products and therefore reserve the right to change designs and specifications without notice.
-

Address Inquires to:

HITACHI SUMITOMO

SCX2500

HYDRAULIC CRAWLER CRANE

Transport Data

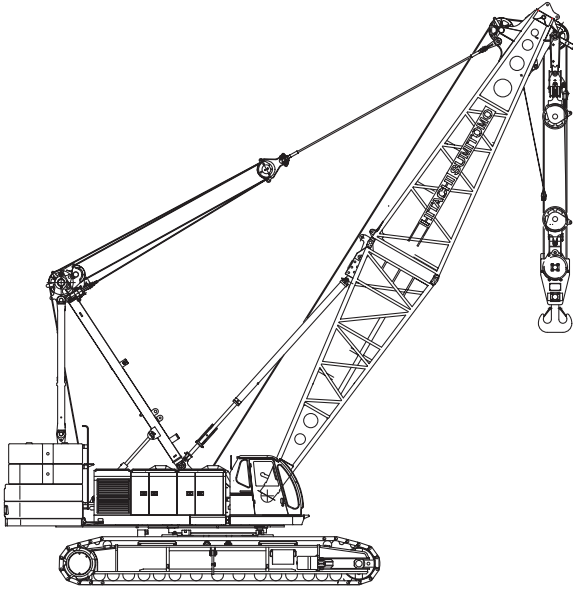
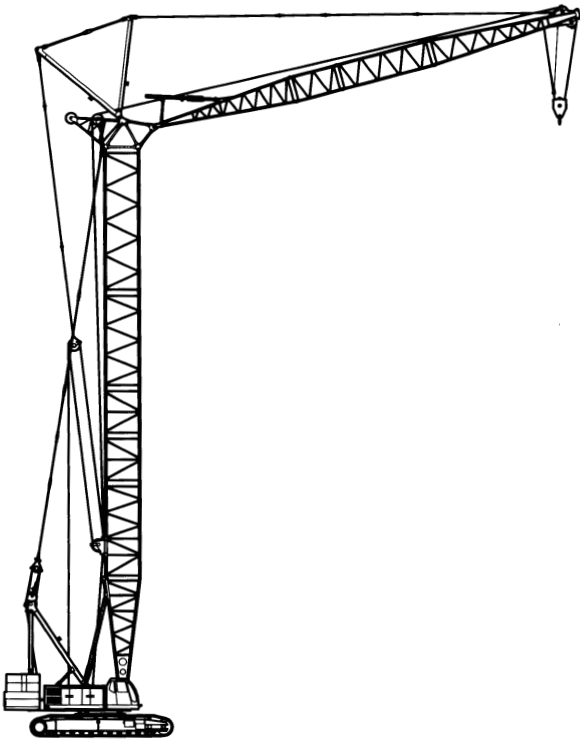
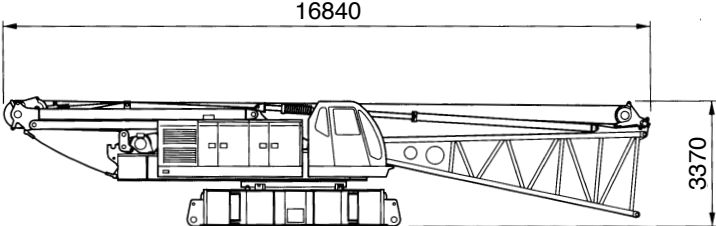
Description	Dimensions (mm)	Mass (kg)
<p>General Arrangement (w/liftcrane att.)</p>	 <p>(w/15.25m basic boom and 250^t hook block)</p>	<p>206,300 (208,100)*¹</p>
<p>General Arrangement (w/luffing towercrane att.)</p>	 <p>(w/36.55m tower, 27.45m luffing jib and 25^t hook block)</p>	<p>220,300 (222,100)*¹</p>
<p>Superstructure with:</p> <ol style="list-style-type: none"> 1. carbody frame; 2. boom bottom section; 3. two main winches; 4. A-frame gantry; 5. bail & bridle w/cable; 6. carbody jack-up device; 7. front drum cable, and 8. 1.7t aux. weight. 	 <p>16840</p> <p>3370</p> <p>Width:3360</p>	<p>57,100 (58,900)*¹</p>

Note: The figure with mark (*1) is of with two main winches with optional free-fall function.

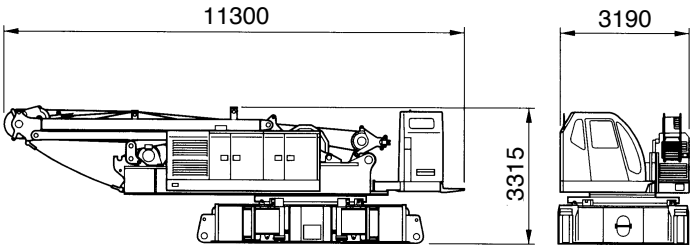
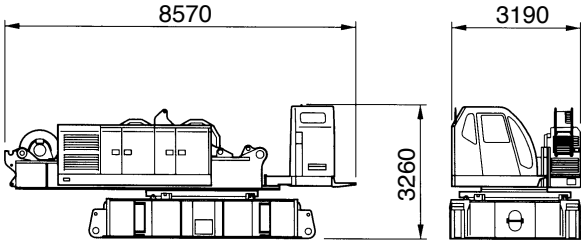
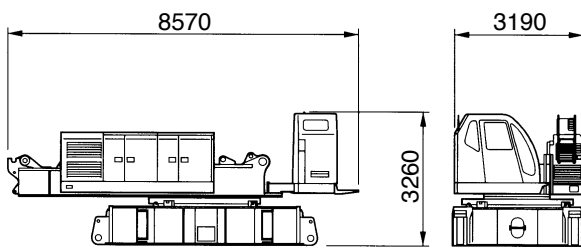
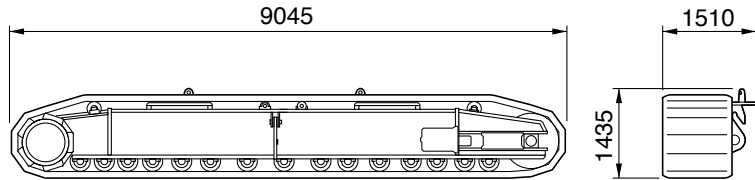
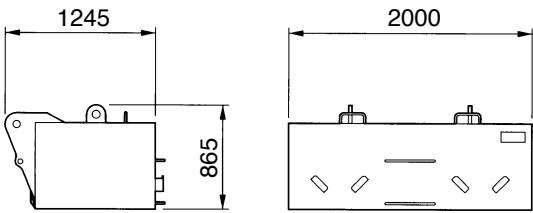
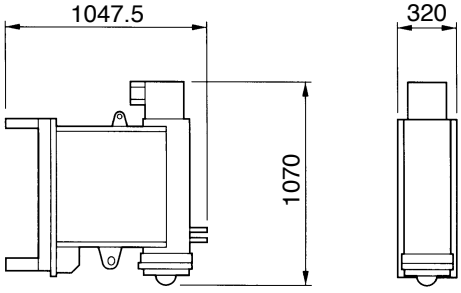
Description	Dimensions (mm)	Mass (kg)
Superstructure with: 1. carbody frame; 2. two main winches; 3. A-frame gantry; 4. bail & bridle w/cable; 5. carbody jack-up device; 6. front drum cable, and 7. 1.7t aux. weight.		53,400 (55,200)* ¹
Superstructure with: 1. carbody frame; 2. two main winches; 3. front drum cable, and 4. 1.7t aux. weight.		44,800 (46,700)* ¹
Superstructure with carbody frame and 1.7t aux. weight.		36,100
Crawler Side Frame		21,500 × 2 sets (21,600 × 2 sets)* ²
Carbody Weight		7,000 × 2 pcs.
Carbody Jack-up Cylinder		600 × 4 pcs.

Note: 1. The figures with mark (*1) are of with two main winches with optional free-fall function.
 2. The figure with mark (*2) is of with optional automatic track tension adjusting device.

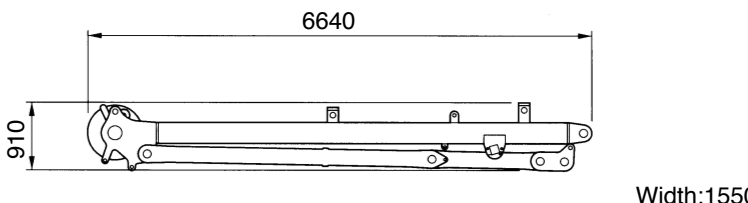
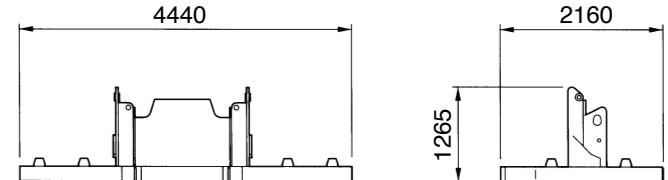
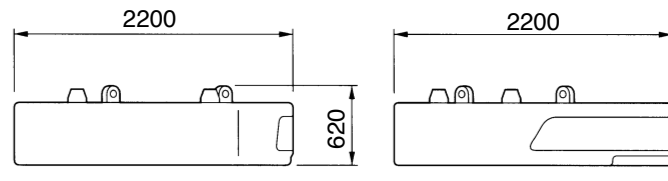
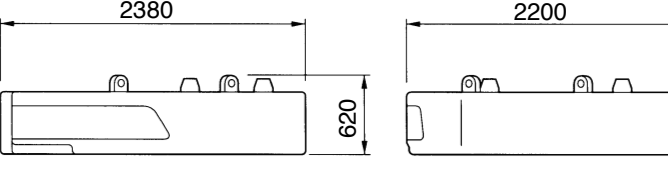
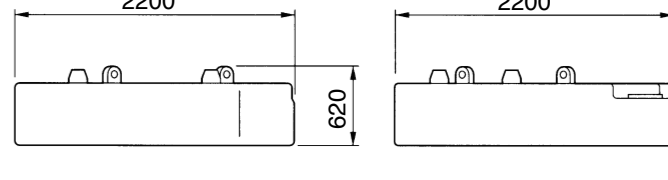
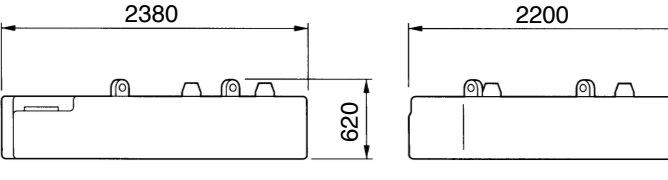
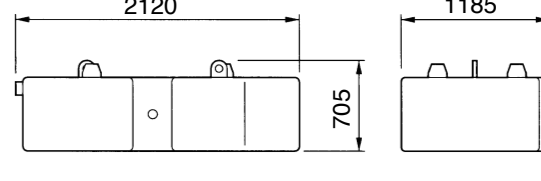
Description	Dimensions (mm)	Mass (kg)
A-frame Gantry	 <p>6640 910 Width:1550</p>	3,800
Base Counterweight	 <p>4440 1265 2160</p>	10,900
Counterweight "A"	 <p>2200 620 2200</p>	10,900
Counterweight "B"	 <p>2380 620 2200</p>	10,900
Counterweight "C"	 <p>2200 620 2200</p>	10,800
Counterweight "D"	 <p>2380 620 2200</p>	10,800
Counterweight "E"	 <p>2120 705 1185</p>	8,500

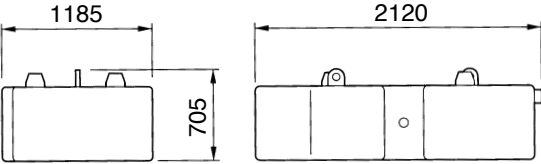
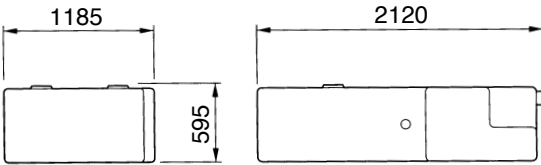
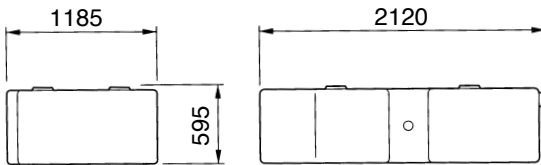
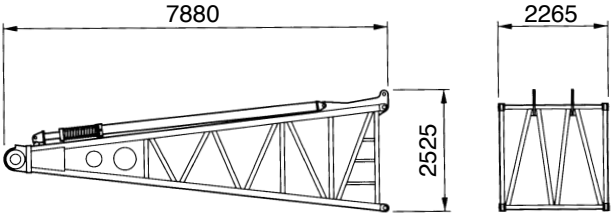
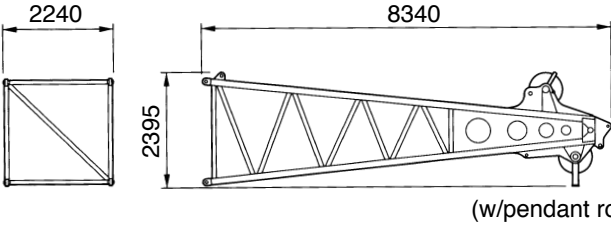
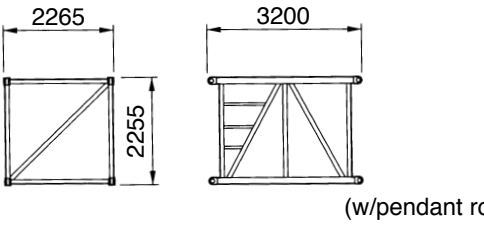
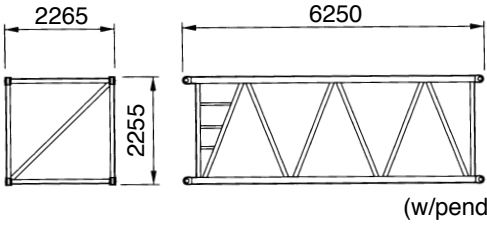
Description	Dimensions (mm)	Mass (kg)
Counterweight "F"		8,100
Counterweight "G"		7,900
Counterweight "H"		7,500
7.60m Boom Bottom Section (w/backstops)		3,800
7.60m HD Boom Top Section		3,400
3.05m HD Boom Extension		1,000
6.10m HD Boom Extension		1,500

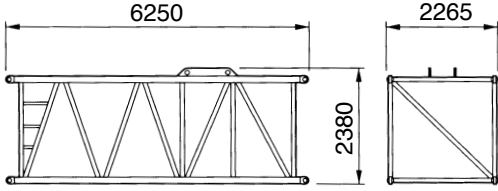
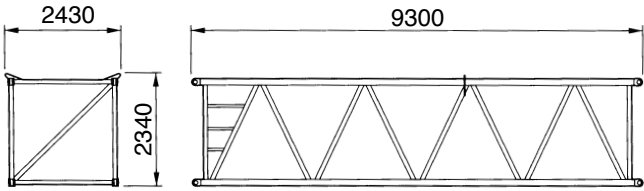
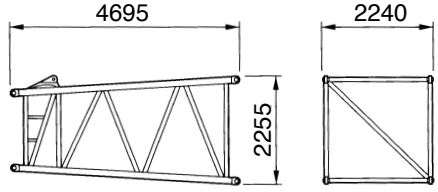
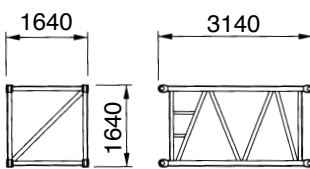
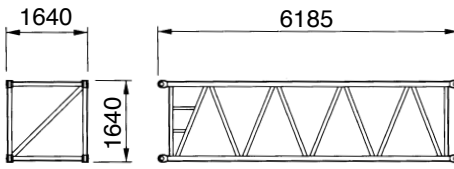
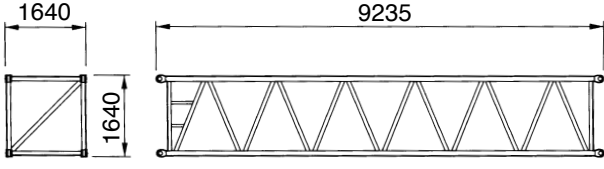
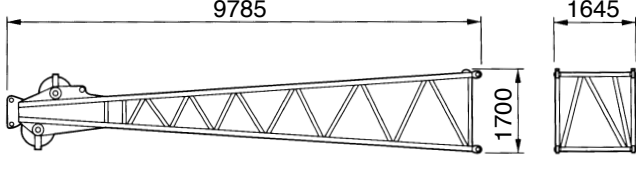
Description	Dimensions (mm)	Mass (kg)
6.10m Special HD Boom Extension (w/lugs for luffing jib bail mounting)	 <p style="text-align: center;">(w/pendant ropes)</p>	2,100
9.15m HD Boom Extension	 <p style="text-align: center;">(w/pendant ropes)</p>	2,100
4.55m Tapered Boom Extension	 <p style="text-align: center;">(w/midpoint links & cables)</p>	1,600
3.05m LD Boom/Luffing Jib Extension	 <p style="text-align: center;">(w/pendant ropes)</p>	400
6.10m LD Boom/Luffing Jib Extension	 <p style="text-align: center;">(w/pendant ropes)</p>	700
9.15m LD Boom/Luffing Jib Extension	 <p style="text-align: center;">(w/pendant ropes)</p>	900
9.15m LD Boom/Luffing Jib Top Section	 <p style="text-align: center;">(w/pendant ropes)</p>	1,800

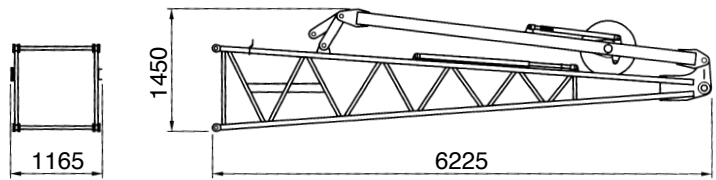
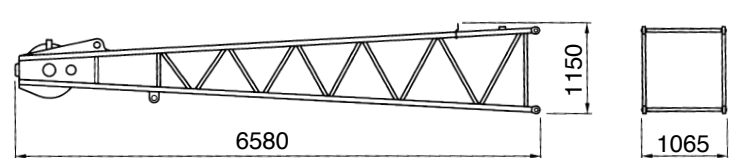
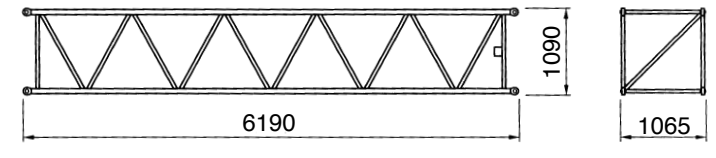
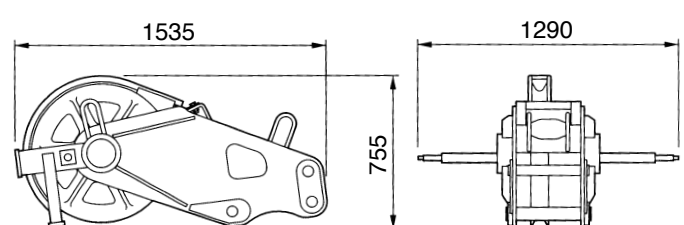
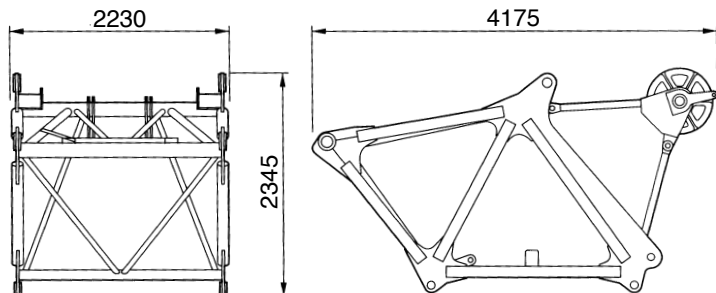
Description	Dimensions (mm)	Mass (kg)
<p>6.10m Fly Jib Bottom section (w/strut)</p>	 <p>(w/pendant ropes)</p>	<p>1,250</p>
<p>6.10m Fly Jib Top section</p>	 <p>(w/pendant ropes)</p>	<p>650</p>
<p>6.10m Fly Jib Extension</p>	 <p>(w/pendant ropes)</p>	<p>400</p>
<p>Aux. Short Jib</p>		<p>300</p>
<p>Tower Head Section</p>		<p>1,500</p>

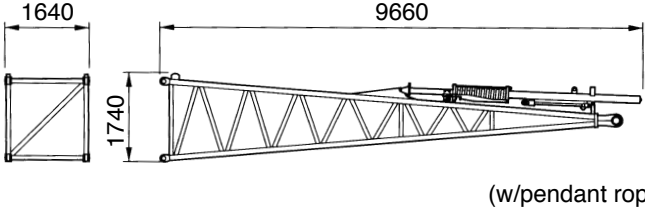
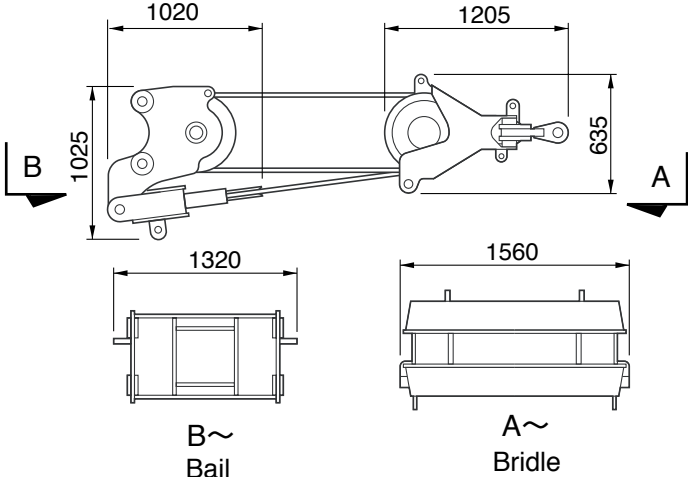
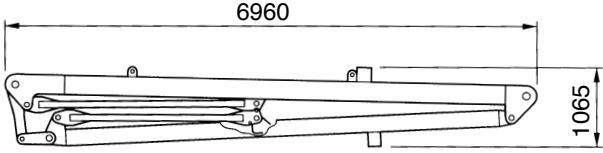
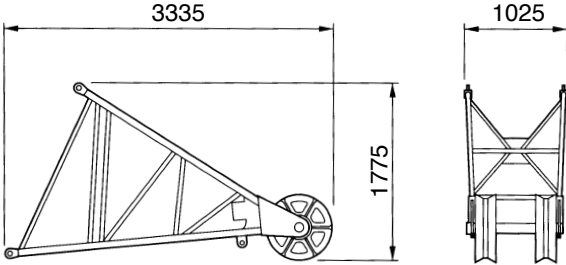
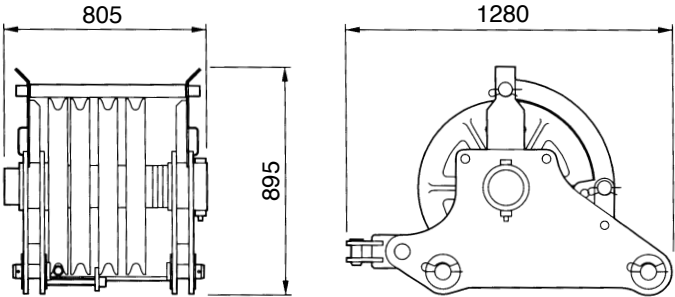
Description	Dimensions (mm)	Mass (kg)
9.15m Luffing Jib Bottom section	 <p style="text-align: center;">(w/pendant ropes)</p>	2,100
Bail & Bridle (w/boom hoist cable)	 <p style="text-align: center;">B~ Bail A~ Bridle</p>	2,600
Front & Rear Posts	 <p style="text-align: center;">Width: 2270</p>	1,600
Roller Bracket		400
Luffing Jib Bail		600

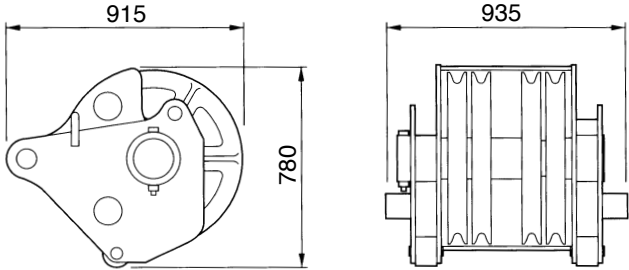
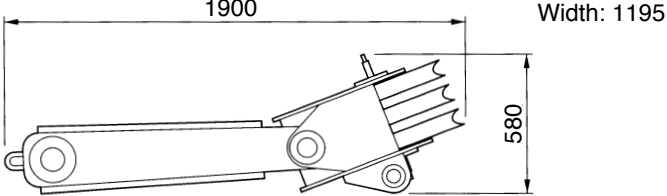
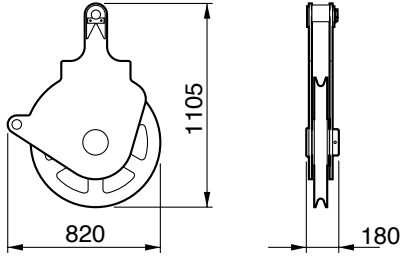
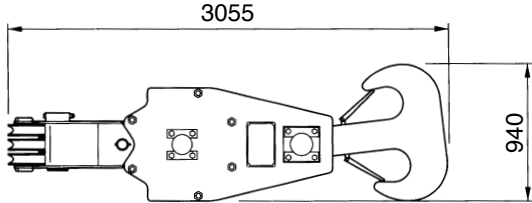
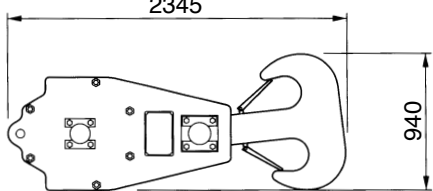
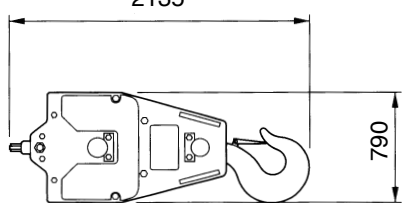
Description	Dimensions (mm)	Mass (kg)
Luffing Jib Bridle		500
Upper 3-hanger Sheave Block	 <p data-bbox="432 779 1252 875">Note: This is pinned to boom head shaft, and available to lift the load exceeding 145t, and up to 200t; when a 250t lift is required, it is required to attach two of "Additional sheave" shown below onto this sheave block.</p>	600
Additional Sheave		170×4 pcs.
200t Hook Block (w/lower 3-hanger sheave block)	 <p data-bbox="432 1435 1230 1480">Note: When attaching two of "Additional sheave" shown above on this 200t hook block, this becomes a 250t hook block.</p>	3,000
145t Hook Block	 <p data-bbox="432 1738 1238 1805">Note: This 145t hook block is available from 200t (or 250t) hook block by means of disattaching the lower 3-hanger sheave block (and two of "Additional sheave").</p>	2,500
80t Hook Block		1,400

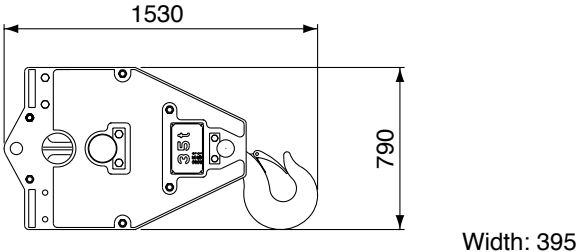
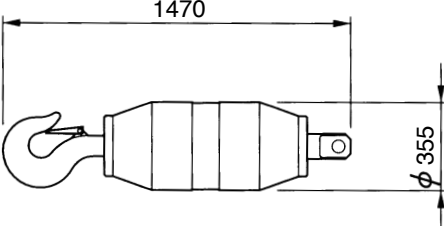
Description	Dimensions (mm)	Mass (kg)
35t/25t Hook Block		900
13.5t Ball Hook Block		600

Note: All of dimensional figures are of with no export packing; in the case that an export packing is done on each cargo, the dimension in height or height/width or height/width/length increases appropriately, and then cubic measurement and mass each comes up accordingly.

MEMO

A series of horizontal dotted lines for writing.

SCX2500

Hitachi Sumitomo Heavy Industries Construction Crane Co., Ltd.

12-14, Ueno 7-chome, Taito-ku, Tokyo 110-0005, Japan

Phone: 81-3-3845-1387 Facsimile: 81-3-3845-1394

• We are constantly improving our products and therefore reserve the right to change designs and specifications without notice.

Address Inquires to:

SCX2500

250-M ton Hydraulic Crawler Crane
Luffing Towercrane Att.



Version A

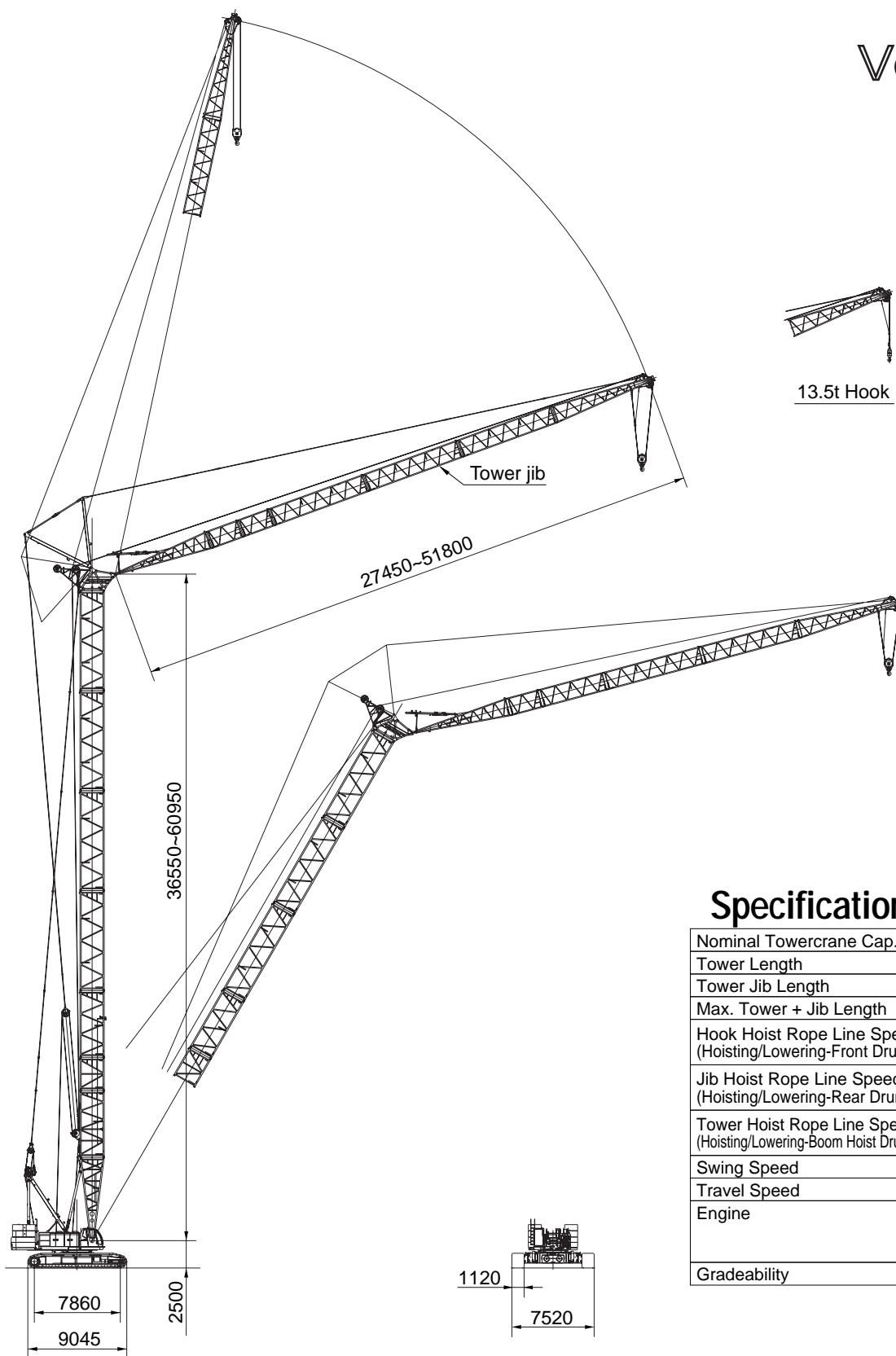

Specification

Nominal Towercrane Cap.	25.0 t x 18.0 m
Tower Length	36.55 m ~ 60.95 m
Tower Jib Length	27.45 m ~ 51.80 m
Max. Tower + Jib Length	60.95 m + 51.80 m
Hook Hoist Rope Line Speed (Hoisting/Lowering-Front Drum)	120 ~ 2.0 m/min
Jib Hoist Rope Line Speed (Hoisting/Lowering-Rear Drum)	51 ~ 2.0 m/min
Tower Hoist Rope Line Speed (Hoisting/Lowering-Boom Hoist Drum)	(24 ~ 1.0 m/min) x 2
Swing Speed	1.7 min. ⁻¹ 1.7 rpm
Travel Speed	1.2/0.8 km/hr
Engine	Mitsubishi 6D24-TL 235kW/2,000min. ⁻¹ 320 ps/2,000rpm
Gradeability	17° (30%)

Luffing Towercrane 25 metric tons

TOWER BOOM:

- Lattice construction, round tubular main chords, alloy, hi-ten steel, with bracing of round steel tubing.
- Tower boom connectionsIn-line pin connections at 2.10m deep by 2.10m wide.
- Special tower boom extensions6.10m long, lattice construction; mounts tower jib bail assembly on upper part, and just pinned next to 7.60m bottom section. Available to use as liftcrane boom extension. Also, 9.15m long special tower boom extension is available.
- Tower boom extensionsAvailable in length 3.05m, 6.10m and 9.15m with tower boom/tower jib hoist pendants. Available to use as liftcrane boom extension.
- Tower head section1.50m long, lattice construction; pinned on top of tower boom. This section pins tower jib and fan-shaped post, and provides one guide sheaves for hoist cable and two guide rollers for tower jib hoist pendant ropes.
- Tower boom length36.55m to 60.95m; the configuration of a 60.95m tower boom as maximum is as under:
 (1) 7.60m heavy-duty tower bottom section × 1 pce. (2) 6.10m special heavy-duty boom extension × 1 pce. (3) 9.15m special heavy-duty boom extension × 1 pce. (4) 3.05m heavy-duty boom extension × 1 pce. (5) 6.1m heavy-duty boom extension × 1 pce. (6) 9.15m heavy-duty boom extension × 3 pcs. (7) 1.50m tower head section × 1 pce.
- Tower boom luffing angle90° thru 60° steplessly.

Note:

- Bottom section of 7.60m long and boom extensions of 3.05m, 6.10m and 9.15m long as necessary to complete liftcrane boom attachment are available from those of luffing towercrane boom attachment.
- In case of converting luffing towercrane boom attachment of 60.95m as max. to liftcrane boom attachment 88.40m as maximum as available, four items of each one of 4.55m tapered boom extension, 6.10m light-duty boom extension, 9.15m light-duty boom extension and 9.15m light-duty tapered top section are only additionally required.

TOWER JIB:

- Lattice construction, round tubular main chords, alloy hi-ten steel, with bracing of round steel tubing.
- Tower jib connectionsIn-line pin connections at 1.55m deep by 1.55m wide.
- Basic tower jibThree-pieces, 27.45m basic length; 9.15m bottom section, one 9.15m light-duty boom extension and 9.15m light-duty tapered top section.
- Tower jib top head machinerySingle head and one guide sheaves mounted on anti-friction bearings.
- Tower jib extensionsAvailable in 3.05m, 6.10m and 9.15m lengths with pendants.
- Maximum tower jib length51.80m; a 51.80m tower jib as maximum is as per following combination. (1) 9.15m light-duty tower jib bottom section × 1 pce. (2) 3.05m light-duty boom extension × 2 pcs. (3) 9.15m light-duty boom extension × 3 pcs. (4) 9.15m light-duty tower jib top section × 1 pce.
- Tower boom luffing angleAvailable from 15° thru 75° (to ground).

FAN-SHAPED POST:

All-welded construction; pinned to tower head section. This serves as mechanical connection for tower jib hoisting and lowering motions.

TOWER JIB BAIL AND BRIDLE:

All-welded construction; provided with larger sheaves of a 22.9 D/d ratio on both bail and bridle for 8-part tower jib hoist rope reeving. Bail mounted on 6.10m special tower boom extensions, and bridle suspended between an 8-part tower jib hoist rope and pendant ropes connecting to tower post.

HOOK BLOCKS:

To be selected from 35/25ton and 13.5ton hook blocks (as same as those of the HOOK BLOCKS mentioned in to "Crane 250 metric tons" of separate SCX2500 SPECIFICATIONS).

DRUM DATA:

See DRUM DATA mentioned into page 7 of separate SCX2500 SPECIFICATIONS. In case that machine is operated under luffing towercrane attachment, rope line speed of rear main drum (as used for tower jib hoisting/lowering motion) must be changed to "51–2.0m/min".

HOIST REEVING:

	Towercrane hoist	
No. of part line	2	1
Max. load (ton)	25.0	13.5

CABLES:

- Front drumP-S (19)+39×P7, non-spin type, 28mm dia./410m long, breaking load 755kN (77.0t).
- Rear drumIWRC 6×P-WS (31), 28mm dia., breaking load 657kN(67.0t). Length of cable is as under:
 With liftcrane application w/aux. short jib180m.
 With liftcrane application w/fly jib and aux. short jib300m.
- Boom hoist drumSame as that of liftcrane application.

Note: When converting luffing towercrane att. to liftcrane application, these rear drum cables of IWRC 6×P-WS (31) specification shown above are only available to use under aux. short jib/fly jib applications.

WORKING WEIGHT:

Approx. 225ton with 60.95m tower boom, 51.80m tower jib, 86.3ton counterweight, 1.7ton aux. weight, 14.0ton carbody weight, 1,120mm wide track shoes and 35/25t hook block.

GROUND PRESSURE:

121kPa <1.23kg/cm²> under a 225ton working weight mentioned above.

Luffing Towercrane Capacities

■ w/36.55m Tower

Jib length (m) Tower angle (°) Working radius (m)	27.45				30.50			
	90	80	70	60	90	80	70	60
10.0	25.0/10.8				25.0/11.6			
12.0	25.0				25.0			
14.0	25.0				25.0			
16.0	25.0				25.0			
18.0	25.0				24.2			
20.0	24.1	23.4/21.5			23.3			
22.0	23.1	23.1			22.4	21.7/22.8		
24.0	20.5	20.5			20.7	20.7		
26.0	18.3	18.3			18.4	18.4		
28.0	15.7	16.5			16.6	16.6		
30.0	13.7/28.7	15.0	14.1/31.5		15.0	15.0		
32.0		13.8	13.8		12.0/31.6	13.7	13.0/33.3	
34.0		12.7	12.7			12.6	12.6	
36.0		11.9/35.7	11.8			11.7	11.7	
38.0			11.0			10.8	10.8	
40.0			10.3	10.0/40.7		10.6/38.6	10.1	
42.0			9.7/41.7	9.6			9.5	9.2/42.8
44.0				9.1			8.9	8.9
46.0				8.6			8.7/44.7	8.4
48.0				8.3/47.4				7.9
50.0								7.5
52.0								7.4/50.3

(EC401059)

■ w/39.60m Tower

Jib length (m) Tower angle (°) Working radius (m)	27.45				30.50				33.50			
	90	80	70	60	90	80	70	60	90	80	70	60
10.0	25.0/10.8				25.0/11.6							
12.0	25.0				25.0				25.0/12.4			
14.0	25.0				25.0				25.0			
16.0	25.0				25.0				24.2			
18.0	25.0				24.2				23.4			
20.0	24.1				23.3				22.6			
22.0	23.1	23.1			22.4	21.3/23.3			21.8			
24.0	20.5	20.5			20.7	20.7			21.0	20.2/24.6		
26.0	18.2	18.2			18.4	18.4			18.6	18.6		
28.0	16.0	16.4			16.5	16.5			16.7	16.7		
30.0	13.6/28.7	15.0			15.0	15.0			15.1	15.1		
32.0		13.7	13.4/32.6		11.8/31.6	13.7			13.8	13.8		
34.0		12.6	12.6			12.6	12.4/34.3		11.8	12.7		
36.0		11.7	11.7			11.6	11.6		10.8/34.4	11.7	11.7/36.1	
38.0		11.6/36.2	10.9			10.8	10.8			10.9	10.9	
40.0			10.2			10.3/39.2	10.0			10.1	10.1	
42.0			9.6	9.5/42.2			9.4			9.5	9.5	
44.0			9.4/42.8	9.0			8.8	8.7/44.4		9.4/42.1	8.9	
46.0				8.5			8.4/45.7	8.3			8.3	8.2/46.5
48.0				8.1				7.8			7.9	7.9
50.0				7.9/48.9				7.4			7.7/48.7	7.4
52.0								7.1/51.8				7.0
54.0												6.7
56.0												6.6/54.8

(EC401059)

■ w/42.65m Tower

Jib length (m)	27.45				30.50				33.50				36.55			
	90	80	70	60	90	80	70	60	90	80	70	60	90	80	70	60
10.0	25.0/10.8				25.0/11.6											
12.0	25.0				25.0				25.0/12.4				23.6/13.2			
14.0	25.0				25.0				25.0				23.3			
16.0	25.0				25.0				24.2				22.6			
18.0	25.0				24.2				23.4				21.9			
20.0	24.1				23.3				22.6				21.2			
22.0	23.1	22.4/22.5			22.4	20.8/23.8			21.8				20.5			
24.0	20.4	20.4			20.6	20.6			20.9	19.6/25.1			19.8			
26.0	18.2	18.2			18.3	18.3			18.6	18.6			18.6	18.2/26.4		
28.0	16.3	16.4			16.5	16.5			16.6	16.6			16.6	16.6		
30.0	13.7/28.7	14.9			14.9	14.9			15.1	15.1			15.0	15.0		
32.0		13.7	12.8/33.6		12.0/31.6	13.6			13.8	13.8			13.7	13.7		
34.0		12.6	12.6			12.5	11.8/35.4		12.0	12.6			12.5	12.5		
36.0		11.7	11.7			11.6	11.6		11.0/34.4	11.7	11.2/37.1		11.6	11.6		
38.0		11.4/36.7	10.9			10.7	10.7			10.8	10.8		9.7/37.3	10.7	10.3/38.9	
40.0			10.2			10.1/39.7	10.0			10.1	10.1			9.9	9.9	
42.0			9.5	9.1/43.7			9.4			9.4	9.4			9.3	9.3	
44.0			9.0/43.8	9.0			8.8	8.3/45.9		9.2/42.6	8.8			8.7	8.7	
46.0				8.5			8.3	8.3			8.3			8.2/45.6	8.1	
48.0				8.0			8.1/46.8	7.8			7.8	7.8			7.6	
50.0				7.6				7.4			7.5/49.7	7.4			7.2	7.2/50.2
52.0				7.5/50.4				7.0				7.0			6.8	6.8
54.0								6.7/53.4				6.6			6.7/52.7	6.4
56.0												6.3				6.1
58.0												6.3/56.3				5.8
60.0																5.6/59.2

(EC401059)

■ w/45.70m Tower

Jib length (m)	27.45				30.50				33.50				36.55				39.60				
	90	80	70	60	90	80	70	60	90	80	70	60	90	80	70	60	90	80	70	60	
10.0	25.0/10.8				25.0/11.6																
12.0	25.0				25.0				25.0/12.4				23.4/13.2								
14.0	25.0				25.0				24.8				23.1				21.6				
16.0	25.0				25.0				24.0				22.4				21.0				
18.0	25.0				24.2				23.2				21.7				20.4				
20.0	24.1				23.3				22.4				21.0				19.8				
22.0	23.1	21.6/23.1			22.4				21.6				20.3				19.2				
24.0	20.4	20.4			20.6	20.1/24.4			20.8	18.8/25.7			19.6				18.6				
26.0	18.1	18.1			18.3	18.3			18.5	18.5			18.5	17.6/26.9			18.0				
28.0	16.3	16.3			16.4	16.4			16.6	16.6			16.6	16.6			16.5	16.3/28.2			
30.0	13.9/28.7	14.9			14.9	14.9			15.0	15.0			15.0	15.0			14.9	14.9			
32.0		13.6			12.2/31.6	13.6			13.7	13.7			13.6	13.6			13.6	13.6			
34.0		12.5	12.2/34.7			12.5			12.1	12.6			12.5	12.5			12.4	12.4			
36.0		11.6	11.6			11.5	11.3/36.4		11.1/34.4	11.6			11.5	11.5			11.5	11.5			
38.0		11.1/37.3	10.8			10.7	10.7			10.8	10.7/38.2		9.8/37.3	10.6	9.9/39.9		10.6	10.6			
40.0			10.1			9.9	9.9			10.0	10.0			9.9	9.9		9.0	9.8	9.3/41.7		
42.0			9.5			9.9/40.2	9.3			9.4	9.4			9.2	9.2		8.8/40.2	9.2	9.2		
44.0			8.9	8.6/45.3			8.7			9.0/43.2	8.8			8.6	8.6			8.6	8.6		
46.0			8.7/44.9	8.4			8.2	7.9/47.4			8.2			8.1	8.1			8.0	8.0		
48.0				8.0			7.8/47.8	7.7			7.8	7.4/49.6		8.1/46.1	7.6			7.5	7.5		
50.0				7.6				7.3			7.3	7.3			7.1	6.8/51.7		7.3/49.1	7.1		
52.0				7.2/51.9				6.9			7.2/50.8	6.9			6.7	6.7			6.7	6.3/53.9	
54.0								6.6				6.6			6.4/53.7	6.4			6.3	6.3	
56.0								6.4/54.9				6.3				6.0			6.0	6.0	
58.0												6.0/57.8				5.7			5.9/56.7	5.7	
60.0																5.4				5.4	
62.0																5.3/60.8					5.1
64.0																					4.9/63.7

(EC401059)

■ w/54.85m Tower

Jib length (m)	27.45				30.50				33.50				36.55			
Tower angle	90	80	70	60	90	80	70	60	90	80	70	60	90	80	70	60
Working radius (m)																
10.0	25.0/10.8				25.0/11.6											
12.0	25.0				25.0				24.8/12.4				22.8/13.2			
14.0	25.0				25.0				24.2				22.5			
16.0	25.0				24.5				23.4				21.8			
18.0	24.9				23.6				22.6				21.1			
20.0	23.9				22.7				21.8				20.4			
22.0	22.9				21.8				21.0				19.7			
24.0	20.2	19.4/24.7			20.4				20.2				19.0			
26.0	18.0	18.0			18.1	18.1			18.4	17.2/27.2			18.3			
28.0	16.2	16.2			16.3	16.3			16.4	16.4			16.4	16.0/28.5		
30.0	14.3/28.7	14.7			14.7	14.7			14.9	14.9			14.8	14.8		
32.0		13.5			12.5/31.6	13.4			13.6	13.6			13.5	13.5		
34.0		12.4				12.3			12.4	12.4			12.3	12.3		
36.0		11.5	10.7/37.8			11.4			11.4/34.4	11.5			11.4	11.4		
38.0		10.7	10.7			10.5	10.0/39.5			10.6			10.1/37.3	10.5		
40.0		10.3/38.9	10.0			9.8	9.8			9.9	9.4/41.3			9.7		
42.0			9.3			9.2/41.8	9.2			9.2	9.2			9.1	8.8/43.0	
44.0			8.8				8.6			8.6	8.6			8.5	8.5	
46.0			8.3				8.1			8.4/44.8	8.1			7.9	7.9	
48.0			7.8	7.5/49.8			7.6				7.6			7.5/47.7	7.4	
50.0				7.4			7.2				7.2				7.0	
52.0				7.1			7.0/50.9	6.8			6.8				6.6	
54.0				6.7				6.4			6.5/53.9	6.4/54.1			6.2	
56.0				6.4				6.1				6.1			5.9	5.8/56.3
58.0				6.3/56.5				5.8				5.8			5.8/56.8	5.6
60.0								5.6/59.5				5.5				5.3
62.0												5.3				5.0
64.0												5.2/62.4				4.8
66.0																4.6/65.3

(EC401059)

■ w/54.85m Tower

Jib length (m)	39.60				42.65				45.70				48.75			
Tower angle	90	80	70	60	90	80	70	60	90	80	70	60	90	80	70	60
Working radius (m)																
14.0	21.0				19.2/14.8				16.6/15.6							
16.0	20.4				18.8				16.5				14.9/16.4			
18.0	19.8				18.3				16.0				14.5			
20.0	19.2				17.8				15.6				14.1			
22.0	18.6				17.3				15.2				13.7			
24.0	18.0				16.8				14.7				13.3			
26.0	17.4				16.2				14.3				12.8			
28.0	16.4	14.9/29.8			15.7				13.8				12.4			
30.0	14.8	14.8			14.6	13.9/31.1			13.4				12.0			
32.0	13.4	13.4			13.3	13.3			13.0	12.8/32.4			11.6	11.2/33.7		
34.0	12.3	12.3			12.2	12.2			12.2	12.2			11.2	11.2		
36.0	11.3	11.3			11.2	11.2			11.2	11.2			10.6	10.6		
38.0	10.4	10.4			10.3	10.3			10.3	10.3			9.8	9.8		
40.0	9.3	9.7			9.5	9.5			9.5	9.5			9.1	9.1		
42.0	8.7/40.2	9.0			8.8	8.8			8.8	8.8			8.5	8.5		
44.0		8.4	8.2/44.8		8.1/43.0	8.2			8.2	8.2			7.9	7.9		
46.0		7.9	7.9			7.7	7.6/46.5		7.1/45.9	7.7			7.4	7.4		
48.0		7.4	7.4			7.2	7.2			7.2	7.1/48.3		6.9	6.9		
50.0		6.9	6.9			6.7	6.7			6.7	6.7		6.4/48.7	6.5	6.5	
52.0		6.8/50.6	6.5			6.3	6.3			6.3	6.3			6.1	6.1	
54.0			6.2			6.0/53.6	5.9			5.9	5.9			5.8	5.8	
56.0			5.8				5.6			5.6	5.6			5.4	5.4	
58.0			5.5	5.5/58.4			5.3			5.5/56.5	5.2			5.1	5.1	
60.0			5.3/59.8	5.2			5.0	4.9/60.6			4.9			4.9/59.5	4.8	
62.0				5.0			4.7	4.7			4.7	4.6/62.8			4.6	
64.0				4.7			4.6/62.7	4.5			4.4	4.4			4.3	4.2/64.9
66.0				4.5				4.2			4.2/65.7	4.2			4.1	4.1
68.0				4.3				4.0				3.9			3.9	3.9
70.0				4.2/68.3				3.8				3.7			3.8/68.6	3.7
72.0								3.7/71.2				3.5				3.5
74.0												3.3				3.3
76.0												3.3/74.2				3.1
78.0																3.0/77.1

(EC401059)

■ w/57.90m Tower

Jib length (m) Tower angle Working radius (m)	27.45				30.50				33.50				36.55			
	90	80	70	60	90	80	70	60	90	80	70	60	90	80	70	60
10.0	25.0/10.8				25.0/11.6											
12.0	25.0				25.0				24.6/12.4				22.6/13.2			
14.0	25.0				25.0				24.0				22.3			
16.0	25.0				24.3				23.2				21.6			
18.0	24.7				23.4				22.4				20.9			
20.0	23.7				22.5				21.6				20.2			
22.0	22.7				21.6				20.8				19.5			
24.0	20.2	18.8/25.2			20.4				20.0				18.8			
26.0	17.9	17.9			18.1	17.6/26.5			18.3	16.6/27.8			18.1			
28.0	16.1	16.1			16.2	16.2			16.4	16.4			16.4	15.5/29.1		
30.0	14.4/28.7	14.7			14.7	14.7			14.8	14.8			14.8	14.8		
32.0		13.4			12.6/31.6	13.4			13.5	13.5			13.4	13.4		
34.0		12.3				12.3			12.4	12.4			12.3	12.3		
36.0		11.4				11.3			11.5/34.4	11.4			11.3	11.3		
38.0		10.6	10.3/38.9			10.5				10.6			10.2/37.3	10.4		
40.0		10.1/39.4	9.9			9.7	9.6/40.6			9.8				9.7		
42.0			9.3			9.1	9.1			9.2	9.1/42.3			9.0		
44.0			8.7			9.0/42.3	8.5			8.6	8.6			8.4	8.4/44.1	
46.0			8.2				8.0			8.2/45.3	8.0			7.9	7.9	
48.0			7.8				7.5				7.6			7.4	7.4	
50.0			7.6/49.0	7.1/51.4			7.1			7.1				7.3/48.2	6.9	
52.0				7.0			6.7	6.5/53.5		6.7					6.5	
54.0				6.7				6.4			6.4	6.1/55.7			6.2	
56.0				6.3				6.1			6.2/54.9	6.1			5.8	5.6/57.8
58.0				6.1				5.8				5.8			5.5/57.9	5.5
60.0								5.5				5.5				5.2
62.0								5.4/61.0				5.2				5.0
64.0												5.0/63.9				4.7
66.0																4.5
68.0																4.4/66.9

(EC401059)

■ w/57.90m Tower

Jib length (m) Tower angle Working radius (m)	39.60				42.65				45.70				48.75			51.80		
	90	80	70	60	90	80	70	60	90	80	70	60	90	80	70	90	80	70
14.0	20.8				19.0/14.8				16.6/15.6									
16.0	20.2				18.6				16.5				14.9/16.4			13.6/17.1		
18.0	19.6				18.1				16.0				14.5			13.4		
20.0	19.0				17.6				15.6				14.1			13.0		
22.0	18.4				17.1				15.2				13.7			12.6		
24.0	17.8				16.6				14.7				13.3			12.2		
26.0	17.2				16.0				14.3				12.8			11.8		
28.0	16.3				15.5				13.8				12.4			11.4		
30.0	14.7	14.5/30.3			14.6	13.5/31.6			13.4				12.0			11.0		
32.0	13.4	13.4			13.3	13.3			13.0	12.6/32.9			11.6			10.6		
34.0	12.2	12.2			12.1	12.1			12.2	12.2			11.2	11.1/34.2		10.0	9.5/35.5	
36.0	11.3	11.3			11.1	11.1			11.1	11.1			10.5	10.5		9.3	9.3	
38.0	10.4	10.4			10.2	10.2			10.3	10.3			9.7	9.7		8.7	8.7	
40.0	9.4	9.6			9.5	9.5			9.5	9.5			9.0	9.0		8.1	8.1	
42.0	9.0/40.2	9.0			8.8	8.8			8.8	8.8			8.4	8.4		7.6	7.6	
44.0		8.4	7.9/45.8		8.2/43.0	8.2			8.2	8.2			7.9	7.9		7.1	7.1	
46.0		7.8	7.8			7.6	7.2/47.6		7.2/45.9	7.6			7.3	7.3		6.7	6.7	
48.0		7.3	7.3			7.1	7.1			7.1	6.8/49.3		6.9	6.9		6.3	6.3	
50.0		6.9	6.9			6.7	6.7			6.7	6.7		6.4/48.7	6.4	6.2/51.1	5.9	5.9	
52.0		6.7/51.2	6.5			6.3	6.3			6.3	6.3			6.1	6.1	5.6/51.6	5.6	5.4/52.8
54.0			6.1			5.9	5.9			5.9	5.9			5.7	5.7		5.2	5.2
56.0			5.8			5.9/54.1	5.5			5.5	5.5			5.4	5.4		5.0	5.0
58.0			5.5				5.2			5.3/57.1	5.2			5.1	5.1		4.7	4.7
60.0			5.2	5.2			4.9				4.9			4.8	4.8		4.4	4.4
62.0			5.1/60.8	4.9			4.7	4.6/62.1		4.6				4.5	4.5		4.2	4.2
64.0				4.7			4.4/63.8	4.4		4.4	4.3/64.3			4.3	4.3		4.1/62.9	4.0
66.0				4.4				4.2		4.1	4.1			4.0	4.0			3.8
68.0				4.2				3.9		4.0/66.7	3.9			3.8	3.8			3.6
70.0				4.0/69.8				3.7			3.7			3.6/69.7	3.6			3.4
72.0								3.5			3.5							3.2
74.0								3.5/72.8						3.3				3.2/72.6
76.0													3.1/75.7					

(EC401059)

■ w/60.95m Tower

Jib length (m)	27.45				30.50				33.50				36.55			
Tower angle	90	80	70	60	90	80	70	60	90	80	70	60	90	80	70	60
Working radius (m)																
10.0	25.0/10.8				24.1/11.6											
12.0	25.0				23.9				22.3/12.4				20.6/13.2			
14.0	24.2				23.0				21.7				20.3			
16.0	23.2				22.1				20.9				19.6			
18.0	22.2				21.2				20.1				18.9			
20.0	21.2				20.3				19.3				18.2			
22.0	20.2				19.4				18.5				17.5			
24.0	19.2	18.1/25.7			18.5				17.7				16.8			
26.0	17.9	17.9			17.6	16.9/27.0			16.9				16.1			
28.0	16.1	16.1			16.2	16.2			16.1	15.9/28.3			15.4	14.8/29.6		
30.0	14.4/28.7	14.6			14.6	14.6			14.8	14.8			14.7	14.7		
32.0		13.4			12.6/31.6	13.3			13.5	13.5			13.4	13.4		
34.0		12.3				12.2			12.3	12.3			12.2	12.2		
36.0		11.4				11.3			11.6/34.4	11.4			11.3	11.3		
38.0		10.6	9.9/39.9			10.4				10.5			10.2/37.3	10.4		
40.0		9.9/39.9	9.9			9.7	9.2/41.6			9.8				9.6		
42.0			9.2			9.1	9.1			9.1	8.7/43.4			9.0		
44.0			8.7			8.8/42.9	8.5			8.5	8.5			8.4	8.1/45.1	
46.0			8.2				8.0			8.0/45.8	8.0			7.8	7.8	
48.0			7.7				7.5				7.5			7.3	7.3	
50.0			7.3				7.1				7.1			7.2/48.8	6.9	
52.0			7.3/50.1	6.8/52.9			6.7				6.7				6.5	
54.0				6.6			6.5/53.0	6.2/55.0			6.3				6.1	
56.0				6.3				6.0			6.0	5.8/57.2			5.8	
58.0				6.0				5.7				5.7			5.5	5.3/59.3
60.0				5.8/59.6				5.4				5.4			5.4/58.9	5.2
62.0								5.2					5.2			4.9
64.0								5.1/62.5					4.9			4.7
66.0													4.8/65.4			4.4
68.0																4.2
70.0																4.2/68.4

(EC401059)

■ w/60.95m Tower

Jib length (m)	39.60				42.65			45.70			48.75			51.80		
Tower angle	90	80	70	60	90	80	70	90	80	70	90	80	70	90	80	70
Working radius (m)																
14.0	19.0				17.5/14.8			16.1/15.6								
16.0	18.4				17.1			16.0			14.9/16.4			13.6/17.1		
18.0	17.8				16.6			15.5			14.5			13.4		
20.0	17.2				16.1			15.1			14.1			13.0		
22.0	16.6				15.6			14.7			13.7			12.6		
24.0	16.0				15.1			14.2			13.3			12.2		
26.0	15.4				14.5			13.8			12.8			11.8		
28.0	14.8				14.0			13.3			12.4			11.4		
30.0	14.2	13.8/30.9			13.5			12.9			12.0			11.0		
32.0	13.3	13.3			13.0	12.9/32.2		12.5	12.1/33.5		11.6			10.6		
34.0	12.2	12.2			12.1	12.1		12.0	12.0		11.2	10.9/34.7		10.0		
36.0	11.2	11.2			11.1	11.1		11.1	11.1		10.5	10.5		9.3	9.3	
38.0	10.3	10.3			10.2	10.2		10.2	10.2		9.7	9.7		8.6	8.6	
40.0	9.4	9.6			9.4	9.4		9.4	9.4		9.0	9.0		8.1	8.1	
42.0	9.0/40.2	8.9			8.7	8.7		8.7	8.7		8.4	8.4		7.5	7.5	
44.0		8.3			8.2/43.0	8.1		8.1	8.1		7.8	7.8		7.1	7.1	
46.0		7.8	7.6/46.9			7.6		7.3/45.9	7.6		7.3	7.3		6.6	6.6	
48.0		7.3	7.3			7.1	6.9/48.6		7.1		6.8	6.8		6.2	6.2	
50.0		6.8	6.8			6.6	6.6		6.6	6.5/50.4	6.5/48.7	6.4		5.9	5.9	
52.0		6.5/51.7	6.4			6.2	6.2		6.2	6.2	6.0	6.0	6.0/52.1	5.6/51.6	5.5	5.2/53.9
54.0			6.1			5.8	5.8		5.8	5.8		5.7	5.7		5.2	5.2
56.0			5.7			5.7/54.6	5.5		5.5	5.5		5.3	5.3		4.9	4.9
58.0			5.4				5.2		5.2/57.6	5.1		5.0	5.0		4.6	4.6
60.0			5.1	4.9/61.5			4.9			4.8		4.7	4.7		4.4	4.4
62.0			4.9/61.9	4.9			4.6			4.6		4.7/60.5	4.5		4.1	4.1
64.0				4.6			4.4			4.3			4.2		4.0/63.5	3.9
66.0				4.4			4.3/64.8			4.1			4.0			3.7
68.0				4.2						3.9/67.8			3.8			3.5
70.0				3.9									3.6			3.3
72.0					3.8/71.3								3.5/70.7			3.2
74.0																3.0/73.6

(EC401059)

Notes — Luffing towercrane capacities

1. Capacities included in these charts are the maximum allowable, and are based on machine standing level on firm supporting surface under ideal job conditions.
2. Capacities are in metric tons, and are not more than based on 78% of minimum tipping loads except the figures surrounded by bold lines which are based on the other factor of machine structural strength limitation.
3. Capacities are based on freely suspended loads and make no allowance for such factors as the effect of wind, sudden stopping of loads, supporting surface conditions, and operating speeds. Operator must reduce load ratings to take such conditions into account. Deduction from rated capacities must be made for weight of hook block, weighted ball/hook, sling, spreader bar, or other suspended gear. Hook block weight is as follows;
35/25t0.9ton 13.5t0.6ton
4. An 86.3ton counterweight, 1.7ton aux.weight and 14.0ton carbody weight are required.
5. All capacities are rated for 360° swing.
6. Least stable rated condition is over the side.
7. Attachment must be erected and lowered over the front of the crawler mounting.
8. Working radii shown above are at loading condition.
9. The machine can be steplessly operated at tower angle between 60 and 90 degrees safely; towercrane capacities available under any tower angle are automatically set up by a computerized automatic over-load preventing system, Model SML-10.
10. The machine must be operated in accordance with correct tower boom and jib combination shown right.
11. Capacities under single part hoist line are detailed; if required, please consult us, or nearest distributor.

Luffing Towercrane Working Ranges

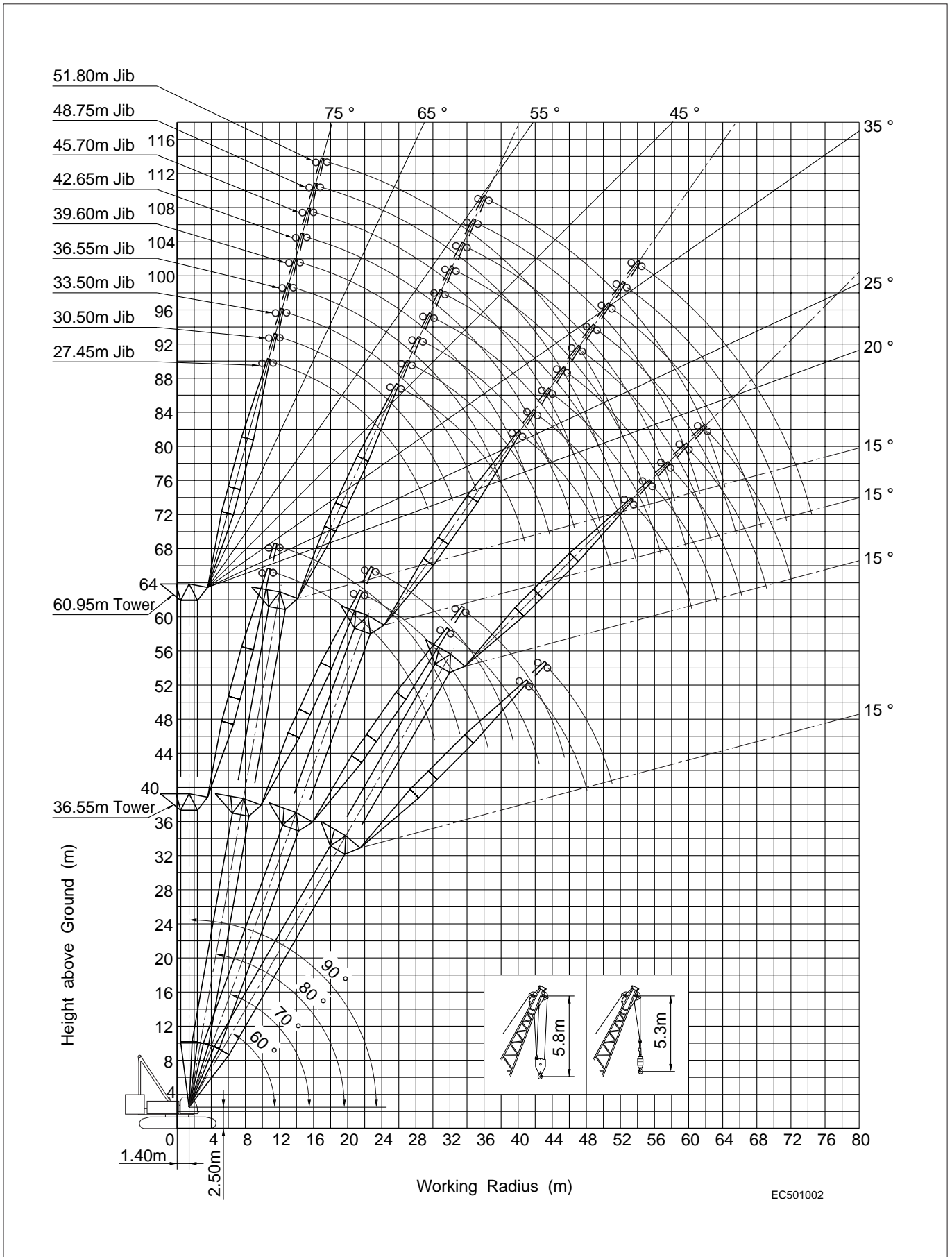

EC501002

Tower Boom and Jib Combination Table

■ Combination Table

Jib length (m) Tower length (m)	27.45	30.50	33.55	36.60	39.60	42.65	45.70	48.75	51.80
36.55			x	x	x	x	x	x	x
39.60				x	x	x	x	x	x
42.65					x	x	x	x	x
45.70						x	x	x	x
48.75							x	x	x
51.80								x	x
54.85									x
57.90									
60.95									

Notes:

The meaning of symbols shown in the above table is as follows;

1. Symbol of “ ” : Possible to luff tower between 90° thru 60°;
2. Symbol of “ ” : Possible to luff tower between 90° thru 70°;
3. Symbol of “x” : Impossible to make any of tower boom and jib combination.

■ Tower Boom Configuration

Boom length (m)	Tower boom combination
36.55	
39.60	
42.65	
45.70	
48.75	
51.80	
54.85	
57.90	
60.95	

Note:

The meaning of figures and symbols shown above is as follows:

- : 7.60m heavy-duty tower bottom section
- : 1.50m tower head section
- : 9.15m heavy-duty boom extension
- : 6.10m heavy-duty boom extension
- : 3.05m heavy-duty boom extension
- : 9.15m special heavy-duty boom extension
- : 6.10m special heavy-duty boom extension

■ Tower Jib Boom Configuration

Boom length (m)	Tower jib boom combination
27.45	
30.50	
33.50	
36.55	
39.60	
42.65	
45.70	
48.75	
51.80	

Note:

The meaning of figures and symbols shown above is as follows:

- : 9.15m light-duty tower jib bottom section
- : 9.15m light-duty tower jib top section
- : 9.15m light-duty boom extension
- : 6.10m light-duty boom extension
- : 3.05m light-duty boom extension

Liftcrane Capacities 250 metric tons

■ w/7.60m Tapered Crane Heavy Top Section

Boom length (m) Working radius (m)	15.25	18.30	21.35	24.40	27.45	30.50	33.50	36.55	39.60	42.65	45.70	48.75	51.80	54.85	57.90	60.95	64.00	67.05	70.10	73.15	
4.6	250.0																				
5.0	230.7	220.4/5.2	198.4/5.7																		
6.0	189.4	189.2	189.0	180.0/6.2	167.2/6.8																
7.0	163.6	163.4	163.2	162.9	162.6	145.0/7.3	139.0/7.8														
8.0	143.8	143.6	143.5	143.2	142.9	143.2	138.2	125.0/8.3	115.1/8.9												
9.0	128.2	128.0	127.9	127.6	127.3	127.6	127.3	123.8	114.8	105.2/9.4											
10.0	115.6	115.4	115.3	115.0	114.7	115.0	114.7	114.5	112.0	103.8	95.0/9.9	87.4/10.5	80.2/11.0	73.7/11.5							
12.0	89.6	89.5	89.3	89.2	89.0	89.5	89.3	89.4	89.2	88.9	89.9	84.8	78.7	73.0	67.9	62.1/12.6	53.7/13.1	52.9/13.6			
14.0	71.3	72.0	71.8	71.7	71.4	71.9	71.7	71.7	71.5	71.2	71.1	71.1	71.6	70.5	65.6	60.7	56.5	52.5	48.3/14.2	44.2/14.7	
16.0	63.0/14.8	60.1	59.8	59.6	59.3	59.8	59.5	59.6	59.4	59.1	58.9	58.9	58.6	58.4	59.0	58.8	54.8	51.0	47.0	43.0	
18.0		53.3/17.5	51.0	50.8	50.5	51.0	50.7	50.7	50.5	50.2	50.1	50.0	49.7	49.5	49.5	49.2	49.7	49.4	43.9	39.6	
20.0			44.4	44.2	43.8	44.3	44.0	44.0	43.8	43.4	43.3	43.2	42.9	42.7	42.7	42.4	42.3	42.2	40.6	36.6	
22.0			44.1/20.1	38.9	38.6	39.0	38.7	38.7	38.5	38.1	38.0	37.9	37.6	37.4	37.3	37.0	37.0	36.8	36.5	33.9	
24.0				37.3/22.7	34.4	34.7	34.4	34.4	34.2	33.8	33.7	33.6	33.2	33.1	33.0	32.7	32.6	32.4	32.1	31.6	
26.0					31.9/25.4	31.3	30.9	30.9	30.6	30.3	30.1	30.0	29.7	29.5	29.4	29.1	29.1	28.9	28.5	28.5	
28.0						28.3	28.0	27.9	27.7	27.3	27.2	27.1	26.7	26.5	26.5	26.1	26.1	25.9	25.5	25.5	
30.0							25.5	25.4	25.2	24.8	24.6	24.5	24.2	24.0	23.9	23.6	23.5	23.3	23.0	23.0	
32.0							24.7/30.7	23.3	23.0	22.6	22.5	22.4	22.0	21.8	21.7	21.4	21.3	21.1	20.8	20.8	
34.0								22.0/33.3	21.2	20.8	20.6	20.5	20.1	19.9	19.8	19.5	19.4	19.2	18.9	18.8	
36.0									19.6/35.9	19.1	18.9	18.8	18.4	18.3	18.2	17.8	17.7	17.5	17.2	17.2	
38.0										17.7	17.5	17.4	17.0	16.8	16.7	16.3	16.3	16.0	15.7	15.7	
40.0										17.3/38.6	16.2	16.1	15.7	15.5	15.4	15.0	14.9	14.7	14.4	14.3	
42.0											15.5/41.2	14.9	14.5	14.3	14.2	13.8	13.8	13.5	13.2	13.1	
44.0												13.9/43.9	13.5	13.3	13.2	12.8	12.7	12.5	12.1	12.1	
46.0													12.5	12.3	12.2	11.8	11.7	11.5	11.2	11.1	
48.0													12.3/46.5	11.5	11.3	11.0	10.9	10.6	10.3	10.2	
50.0														11.1/49.1	10.6	10.2	10.1	9.8	9.5	9.4	
52.0															9.9/51.8	9.5	9.3	9.1	8.7	8.7	
54.0																8.8	8.7	8.4	8.0	7.9	
56.0																8.7/54.4	8.1	7.8	7.3	7.2	
58.0																	7.7/57.1	7.1	6.7	6.5	
60.0																		6.6/59.7	6.1	5.9	
62.0																				5.5	5.3
64.0																				5.4/62.3	4.6
65.0																					4.6

(EC403023)

■ w/9.15m Tapered Crane Light Top Section

Boom length (m) Working radius (m)	73.15	76.20	79.25	82.30	85.35	88.40
14.0	37.5/14.5	34.5/15.0	32.7/15.5			
16.0	35.9	33.5	32.1	31.5/16.1	25.0/16.5	25.0/17.0
18.0	34.3	31.7	30.4	29.7	25.0	25.0
20.0	32.9	30.2	28.9	28.2	25.0	24.1
22.0	31.6	28.9	27.5	26.9	25.0	23.2
24.0	30.2	27.7	26.3	25.7	24.2	22.1
26.0	28.5	26.2	25.3	24.6	23.1	20.9
28.0	26.0	24.9	24.4	23.5	22.1	20.0
30.0	23.8	23.4	23.1	22.3	21.0	18.9
32.0	21.6	21.7	21.6	20.9	19.9	17.9
34.0	19.8	19.8	19.7	19.7	18.7	16.9
36.0	18.2	18.1	18.1	18.1	17.6	15.9
38.0	16.7	16.6	16.6	16.6	16.3	14.8
40.0	15.3	15.3	15.2	15.2	15.2	13.9
42.0	14.2	14.1	14.1	14.1	14.0	13.1
44.0	13.1	13.0	13.0	13.0	12.9	12.3
46.0	12.1	12.1	12.0	12.0	12.0	11.6
48.0	11.2	11.2	11.1	11.1	11.1	10.9
50.0	10.4	10.4	10.3	10.3	10.3	10.2
52.0	9.7	9.7	9.6	9.6	9.5	9.5
54.0	9.0	9.0	8.9	8.9	8.9	8.9
56.0	8.4	8.4	8.3	8.3	8.3	8.3
58.0	7.8	7.8	7.7	7.7	7.7	7.7
60.0	7.3	7.2	7.1	7.1	7.1	7.1
62.0	6.7	6.6	6.6	6.6	6.6	6.6
64.0	6.2	6.1	6.0	6.0	6.0	6.0
66.0	6.0/64.9	5.6	5.6	5.6	5.6	5.6
68.0		5.3/67.5	5.1	5.1	5.1	5.1
70.0			4.7	4.7	4.7	4.7
72.0			4.6/70.2	4.3	4.3	4.3
74.0				4.1/72.8	3.9	3.9
76.0					3.7/74.8	3.5
77.4						3.2

(EC403023)

Notes — Liftcrane capacities

- Capacities included in this chart are the maximum allowable, and are based on machine standing level on firm supporting surface under ideal job conditions.
- Capacities are in metric tons, and are not more than 78% of minimum tipping loads except the figures surrounded by bold lines which are based on other factor of machine structural strength limitation.
- Capacities are based on freely suspended loads and make no allowance for such factors as the effect of wind, sudden stopping of loads, supporting surface conditions, and operating speeds. Operator must reduce load ratings to take such conditions into account. Deduction from rated capacities must be made for weight of hook block, weighted ball/hook, sling, spreader bar, or other suspended gear. Hook block weight is as follows:
 250t.....3.3ton 200t.....3.0ton 145t.....2.5ton
 80t.....1.4ton 35/25t.....0.9ton 13.5t.....0.6ton
- All capacities are rated for 360° swing.
- Least stable rated condition is over the side.
- An 86.3ton counterweight, 1.7ton auxiliary weight, and 14.0ton carbody weight are required for all capacities on this chart.
- Attachment must be erected and lowered over the ends of the crawler mounting.
- Main boom length must not exceed 88.40m.
Maximum boom length when mounting auxiliary short jib is 85.35m.
- Capacities when handling load off main boom head sheaves in case of mounting auxiliary short jib on top of boom are detailed; if required, please consult us or nearest distributor.
- Boom combination shall be in accordance with manufacture's standard described here in "Boom Combination Diagram".

Liftcrane Working Ranges

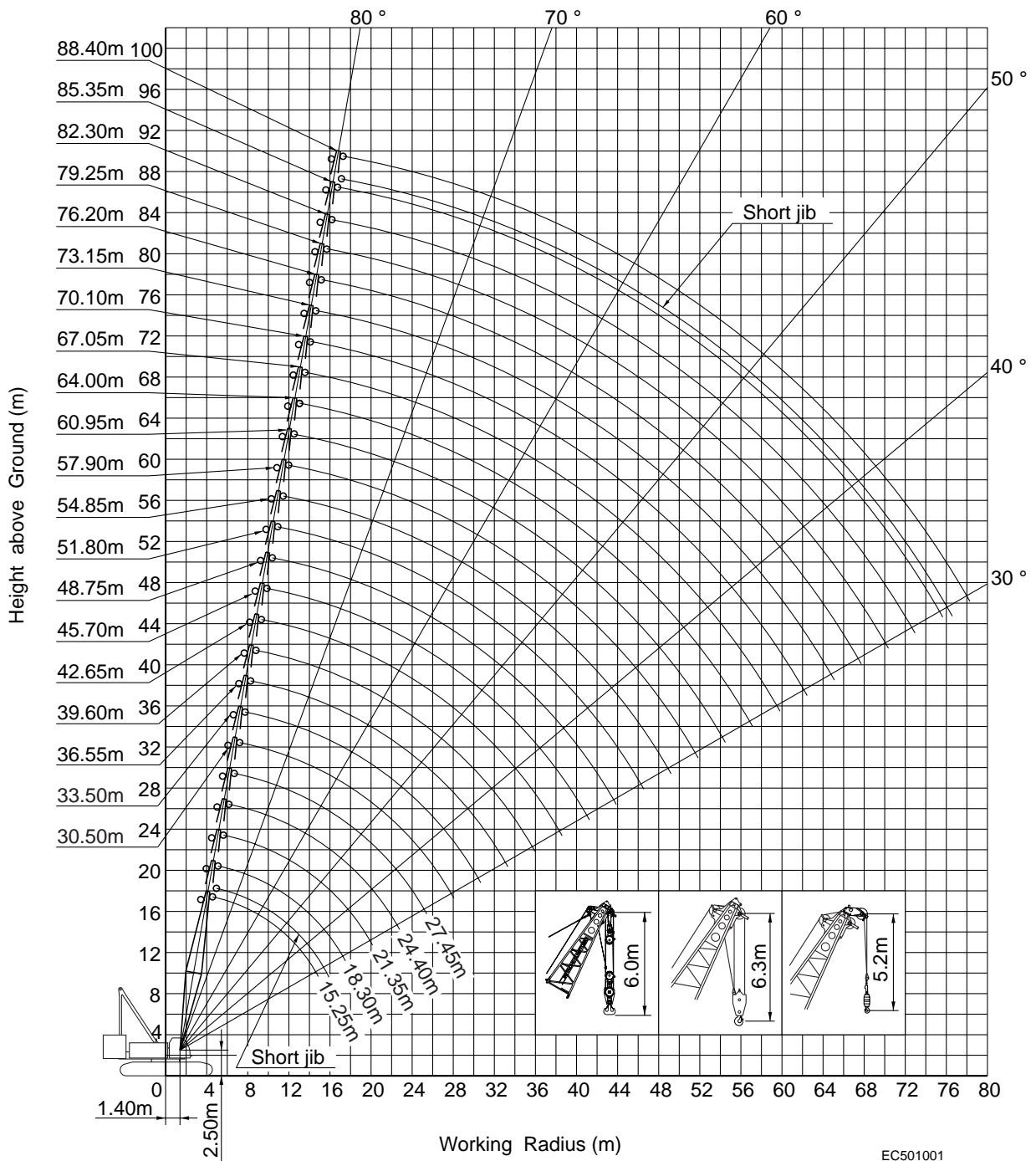

Boom Combination Diagram for Liftcrane

Boom length (m)	Boom combination
15.25	
18.30	
21.35	
24.40	
27.45	
30.50	
33.50	
36.55	
39.60	
42.65	
45.70	
48.75	
51.80	
54.85	
57.90	
60.95	
64.00	
67.05	
70.10	
73.15	
76.20	
79.25	
82.30	
85.35	
88.40	

Note: Whenever fly jib is attached on main boom ranging all the way from 45.70m thru 73.15m, HEAVY-DUTY TAPERED TOP SECTION of 7.60m is required. And, in the case that main boom length of 73.15m as available as the longest is required, a 57.95m long heavy-duty boom extension in total is correspondingly necessary, and its configuration shall be 2 pcs. of 3.05m(3H), 1 pc. of 6.10m(6SH), 1 pc. of 9.15m(9SH) and 4 pcs. of 9.15m(9H) described below in column of 73.15m boom length.

Note:

The meaning of figures and symbols shown above are as follows:

- | | |
|--|---|
| : 7.60m heavy-duty bottom section | : 4.55m tapered boom extension |
| : 7.60m heavy-duty tapered top section | : 9.15m special heavy-duty boom extension |
| : 9.15m light-duty tapered top section | : 6.10m special heavy-duty boom extension |
| : 9.15m heavy-duty boom extension | : 9.15m light-duty boom extension |
| : 6.10m heavy-duty boom extension | : 6.10m light-duty boom extension |
| : 3.05m heavy-duty boom extension | : 3.05m light-duty boom extension |

MEMO

A series of horizontal dotted lines for writing.

Hitachi Sumitomo Heavy Industries Construction Crane Co., Ltd

12-14, Ueno 7-chome, Taito-ku, Tokyo 110-0005, Japan

Phone: 81-3-3845-1387 Facsimile: 81-3-3845-1394

- We are constantly improving our products and therefore reserve the right to change designs and specifications without notice.
- Units in this specification are shown under International System of Units; the figures in parenthesis are under Gravitational System of Units as old one.

Address Inquires to: